

## OPERATING MANUAL

### LPSD18

Sunshine duration  
sensor



EN  
V1.7

## Contents

<b>1</b>	<b>Introduction .....</b>	<b>3</b>
<b>2</b>	<b>Technical specifications.....</b>	<b>4</b>
<b>3</b>	<b>Operating principle.....</b>	<b>5</b>
<b>4</b>	<b>Installation.....</b>	<b>6</b>
4.1	Electrical connections .....	10
<b>5</b>	<b>RS485 Modbus-RTU output.....</b>	<b>12</b>
5.1	Setting the communication parameters .....	12
5.2	Reading the measures with the Modbus-RTU protocol .....	14
5.3	Change of the heating activation temperature .....	15
<b>6</b>	<b>SDI-12 output .....</b>	<b>16</b>
<b>7</b>	<b>Maintenance .....</b>	<b>20</b>
<b>8</b>	<b>Safety instructions .....</b>	<b>21</b>
<b>9</b>	<b>Accessories ordering codes .....</b>	<b>22</b>

## 1 Introduction

The Sunshine Duration sensor LPSD18 measures status and sunshine duration. The WMO (World Meteorological Organization) defines the sunshine duration as the time during which the direct solar radiation exceeds the level of  $120 \text{ W/m}^2$ .

The radiation measurement is performed with an array of photodiodes arranged in a particular geometry which allows to obtain an accurate measurement in any weather conditions. This solution avoids the use of mechanical moving parts and ensures high reliability over time.

The instrument, besides indicating the presence of sun as required by the WMO, measures also direct radiation (SRD), therefore it can be used as a low cost alternative to a pyrheliometer, which use is bound to a solar tracker.

LPSD18 is equipped with a heating element separately powered and galvanically isolated, which prevents the formation of condensation on the glass surface onto which the sensitive elements are placed. For harsh climates, the above-mentioned versions are available with a second heating element (option R, LPSD18.x**R**), which prevents the formation of ice and prevents snow from settling.

The instrument is available in three versions, which differ in the type of output:

Model	OUTPUT					Heating
	RS485 Modbus-RTU	SDI-12	Voltage-free contact	Analog 0...1 V	Digital voltage	
LPSD18.1[R]	√		√			With option <b>R</b> in the code
LPSD18.2[R]	√			√	√	
LPSD18.3[R]		√	√			

**Voltage-free contact:** closed  $\Rightarrow$  SRD  $\geq 120 \text{ W/m}^2$ , open  $\Rightarrow$  SRD  $< 120 \text{ W/m}^2$

**Analog output:** 0...1 V  $\Rightarrow$  0...2000  $\text{W/m}^2$

**Digital voltage output:** 1V  $\Rightarrow$  SRD  $\geq 120 \text{ W/m}^2$ , 0V  $\Rightarrow$  SRD  $< 120 \text{ W/m}^2$

The instrument does not need any positioning adjustment during the year and it can be installed on a mast or placed on a flat base using proper fixing optional accessories.

The application fields are multiple: from the agronomy (agricultural science) to the study the growth of crops, to photovoltaic systems for verifying their performance, to building automations for automatic opening/closing of blinds, shutters and, in general, to all those areas where it is necessary to monitor the presence of sunlight.

## 2 Technical specifications

<b>Sensitive elements</b>	16 Silicon photodiodes
<b>Spectral range</b>	360...1100 nm
<b>Direct radiation SRD measuring range</b>	0...2000 W/m <sup>2</sup>
<b>Accuracy of the measurement of direct radiation</b>	Better than 90% on the monthly total
<b>Accuracy of the measurement of the sunshine duration sensor</b>	Better than 90% on the monthly total
<b>Response time</b>	<1 ms
<b>Threshold value</b>	120 W/m <sup>2</sup>
<b>Sunshine duration resolution</b>	1 s
<b>Power supply Consumption</b>	7...30 Vdc 5mA @ 12V
<b>Heating system Anti-condensation device consumption Antifreeze device consumption</b>	12...15 Vdc 1 W @ 12 V 5 W @ 12 V ON for internal Temp. < 6 °C, OFF for internal Temp. > 10 °C
<b>Internal temperature Measuring range Accuracy</b>	-40...+80 °C ± 0.5 °C
<b>Operating temperature</b>	-40...+80 °C
<b>Weight</b>	0.9 kg
<b>Protection degree</b>	IP66
<b>Outputs</b>	
<b>LPSD18.1</b>	<ul style="list-style-type: none"> <li>• RS485 MODBUS-RTU</li> <li>• Galvanically isolated contact closed = SRD ≥ 120 W/m<sup>2</sup> open = SRD &lt; 120 W/m<sup>2</sup></li> </ul>
<b>LPSD18.2</b>	<ul style="list-style-type: none"> <li>• RS485 MODBUS-RTU</li> <li>• Analog output 0...1 V (0...2000 W/m<sup>2</sup>)</li> <li>• Digital output 0...1 V 1 V = SRD ≥ 120 W/m<sup>2</sup> 0 V = SRD &lt; 120 W/m<sup>2</sup></li> </ul>
<b>LPSD18.3</b>	<ul style="list-style-type: none"> <li>• SDI-12</li> <li>• Galvanically isolated contact closed = SRD ≥ 120 W/m<sup>2</sup> open = SRD &lt; 120 W/m<sup>2</sup></li> </ul>

### 3 Operating principle

The Sunshine Duration LPSD18 is based on the use of 16 sensors arranged in such a way that, in the presence of sun, at least one of the photo-detectors is exposed to sun light directly from the sun (besides the diffusion component).

Those sensors which are not directly illuminated by the sun are used for the measurement of the diffused light that is subtracted from the measurement of the sensor which sees the sun directly to get direct radiation.

The cylindrical glass protects the sensors and the internal circuits of the instrument from the weather and at the same time provides an excellent transparency to sunlight.

In order to avoid the formation of condensation inside the instrument, in addition to the heating element, the LPSD18 is supplied with a cartridge that must be loaded with desiccant material in colloidal silica (Silica-gel).

## 4 Installation

Before installing the sunshine duration sensor, refill the cartridge containing silica-gel crystals.

Do not touch the silica-gel crystals with your hands while refilling the cartridge. Carry out the following instructions in an environment as drier as possible:

1. Unscrew the silica gel cartridge using a coin.
2. Remove the cartridge perforated cap.
3. Open the sachet containing silica gel (supplied with the sunshine duration sensor).
4. Fill the cartridge with the silica gel crystals.
5. Close the cartridge with its own cap, paying attention that the sealing O-ring be properly positioned.
6. Screw the cartridge to the sunshine duration sensor body using a coin.
7. Check that the cartridge is screwed tightly (if not, silica gel life will be reduced).

The figure below shows the operations necessary to fill the cartridge with the silica gel crystals.

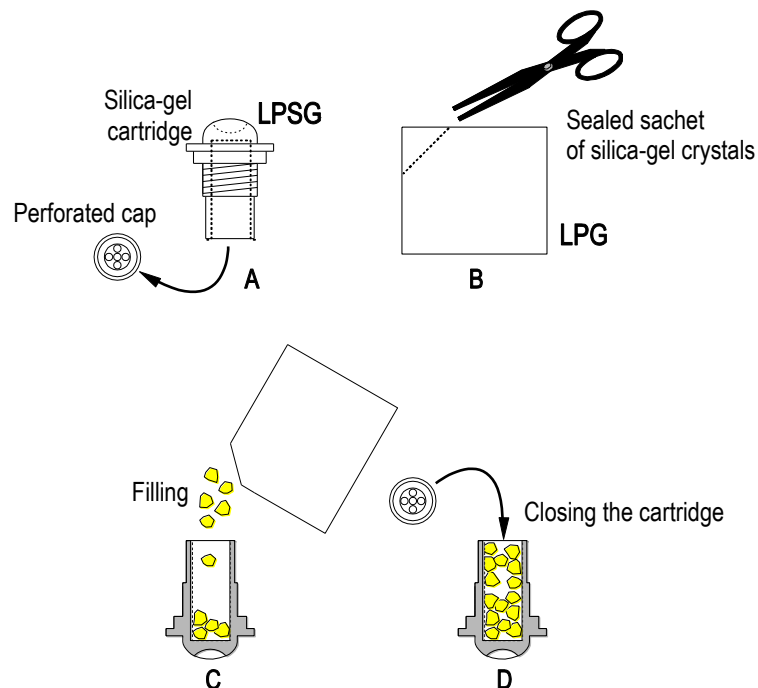

**Fig. 4.1: filling the silica-gel cartridge**

The sunshine duration sensor should be installed in a place easy to be reached for the periodical cleaning of the glass and the maintenance. At the same time, it should be avoided that buildings, trees or obstructions of any kind exceed the horizontal plane on which the sunshine duration is placed. It is acceptable to choose a location where obstacles in the path of the sun from sunrise to sunset is less than 5° from the horizontal plane of the sunshine duration sensor. It should be also checked that there are no reflective elements that may alter the measure.

The LPSD18 does not need any positioning adjustment during the year.

Adjustable supports are available to fit the sensor to the position of the sun to the latitude of the place of installation:

- Installation on the base **LPSD18.O**. The base allows the inclination of the sensor up to 80° (with graduated scale) respect to the vertical. Two adjustable feet and one fixed foot allow the sensor horizontal levelling.

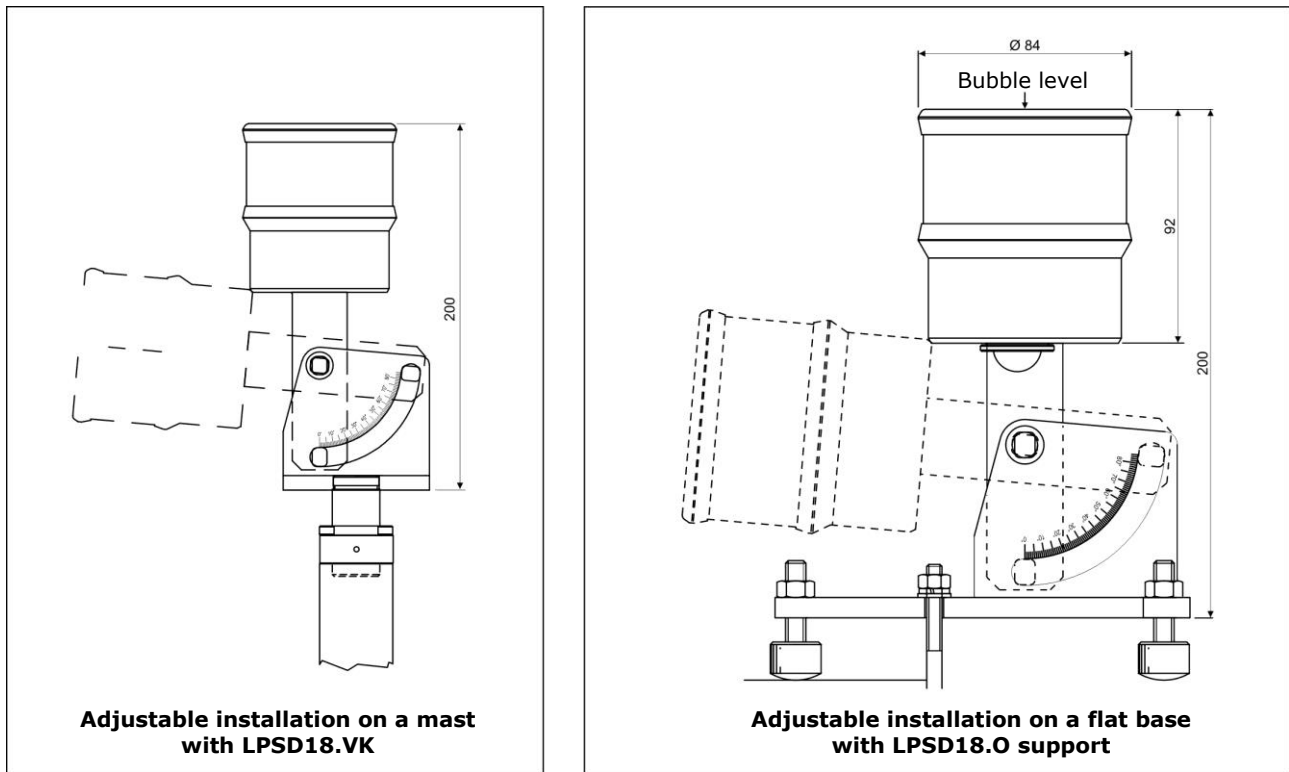

**Fig. 4.2: LPSD18.O support**

- Installation on a vertical  $\varnothing$  40 mm mast by using the **LPSD18.VK** support. The support allows the inclination of the sensor up to 80° (with graduated scale) respect to the vertical and the rotation of the sensor on the horizontal plane.

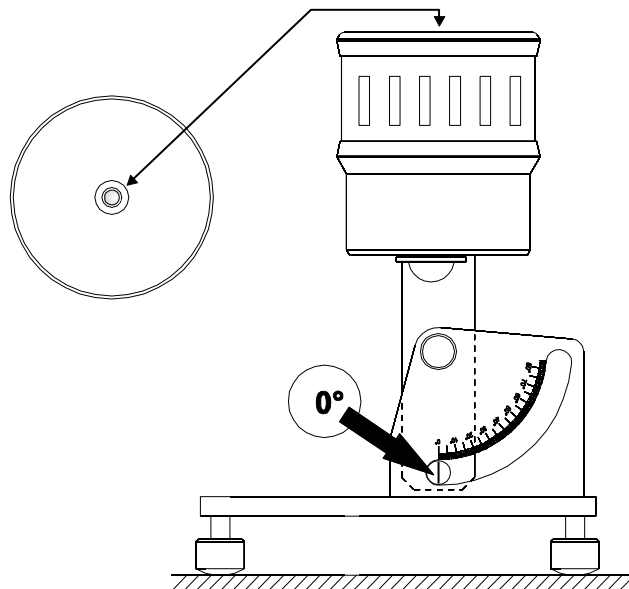

**Fig. 4.3: LPSD18.VK support**



**Fig. 4.4: supports**

Before orienting the Sunshine Duration Sensor to its final position, place it vertically and adjust the base (for installation on a plane) or support (for installation on a  $\varnothing 40$  mm mast) feet so that the level on the upper side of the instrument is perfectly levelled.



**Fig. 4.5: levelling of the Sunshine Duration Sensor**

Orient the Sunshine Duration Sensor so that the index of the graduated scale of the support matches the value ( $90^\circ - \text{Latitude}$ ) and the top (where the spirit level is placed) is directed towards the NORTH pole, if used in the northern hemisphere, or towards south, if used in the southern hemisphere.



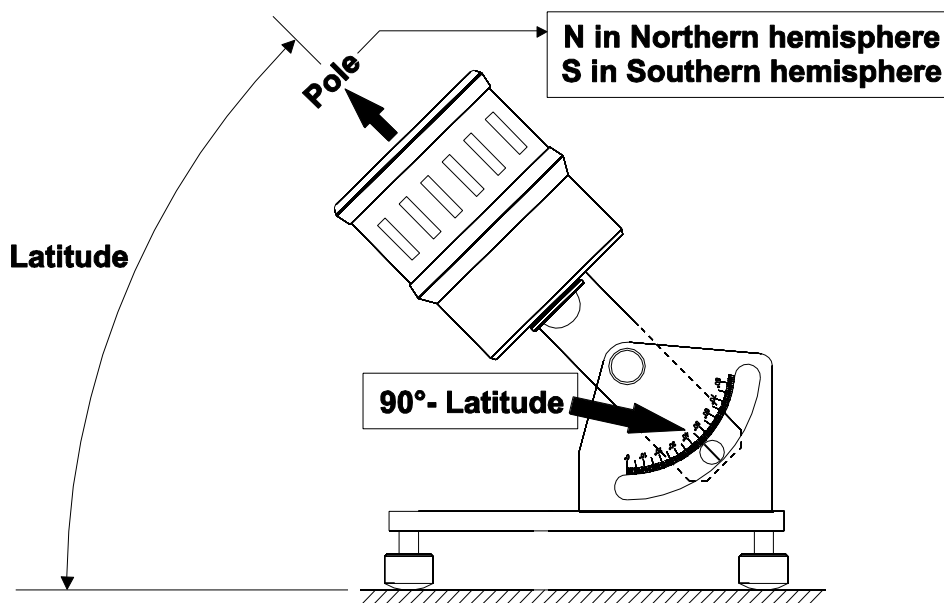

**Fig. 4.6: orientation of the Sunshine Duration Sensor**

The angle that instrument axis should make with respect to the ground is equal to the latitude of the installation site, this way the axis of the instrument will be parallel to the earth axis North-South.

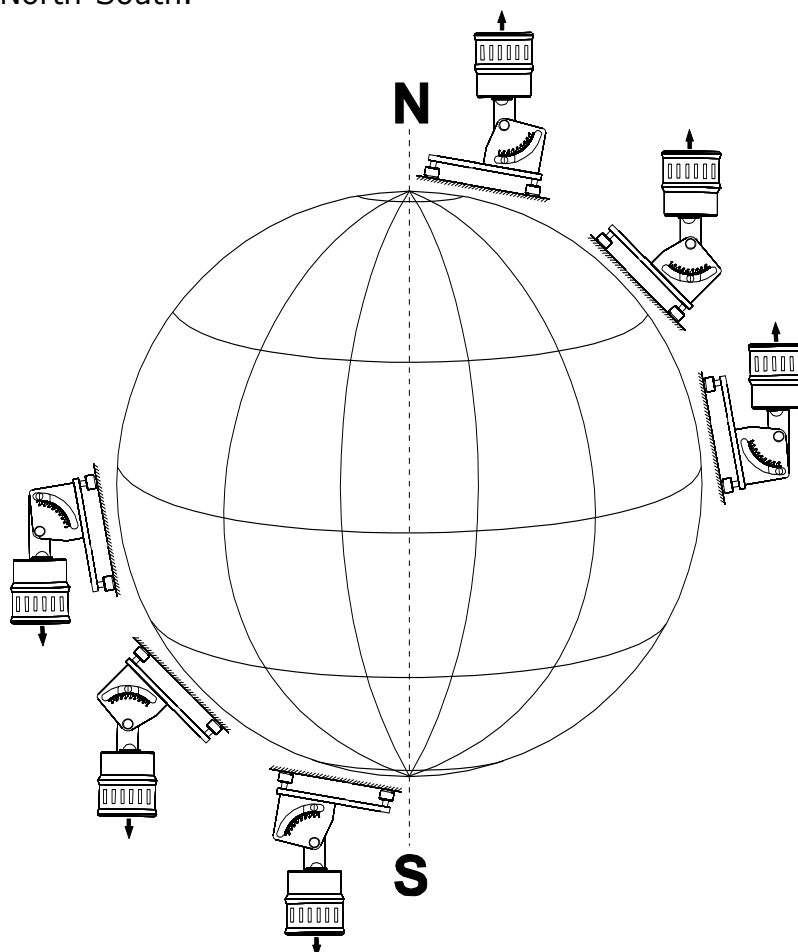

**Fig. 4.7: Sunshine Duration Sensor parallel to the Earth axis**

## 4.1 Electrical connections

The Sunshine Duration Sensor has an 8-pole connector and uses the **CP18... optional** cables with 8-pole connector on one side and open wires on the other side.

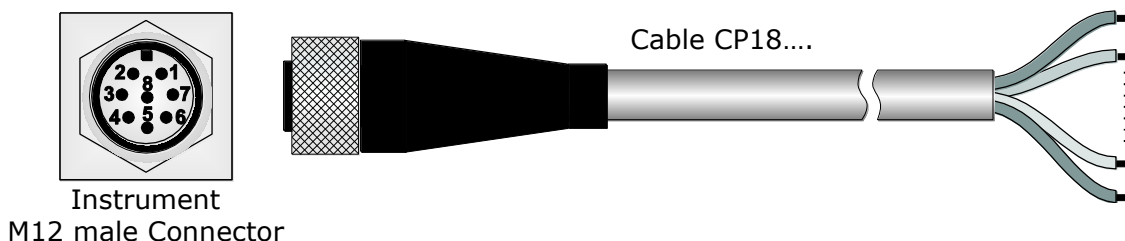
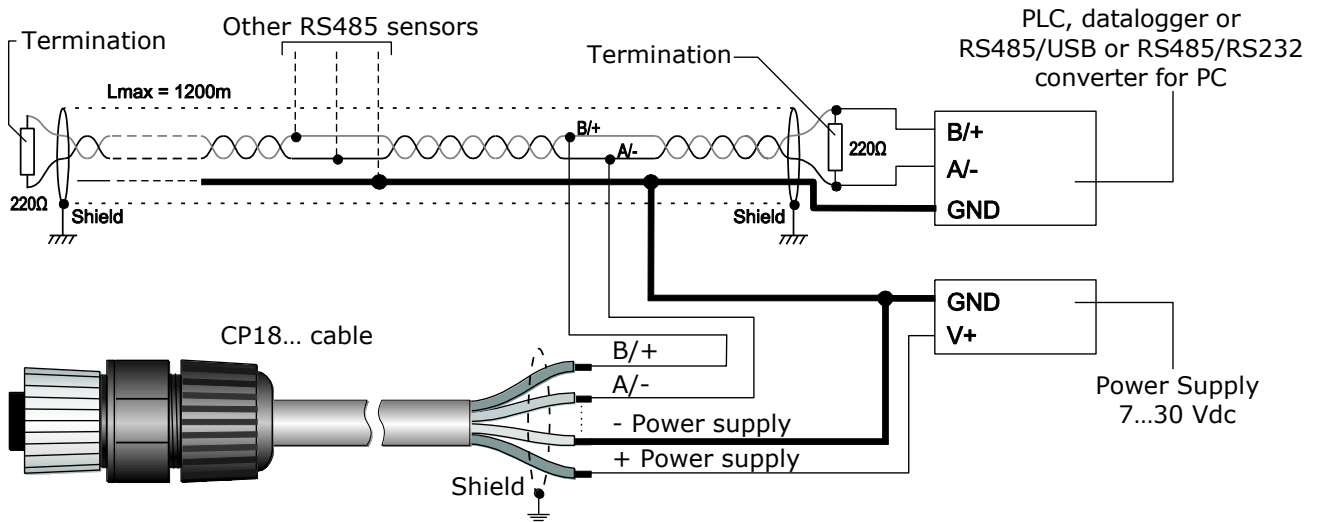

**Fig. 4.8: connections**

Connector pin N°	Function	CP18... cable wire N°/colour
<b>LPSD18.1[R]</b>		
1	Power supply negative	12/Black + 7/Violet + 6/Pink (**)
2	Power supply positive	1/Red + 2/Blue + 4/Grey-Pink (**)
3	Heating (*)	3/Yellow
4	RS485 A/-	9/White
5	RS485 B/+	5/Red-Blue
6	Volt-free contact output	8/Grey
7	Heating (*)	10/Brown
8	Volt-free contact output	11/Green
<b>LPSD18.2[R]</b>		
1	Power supply negative 0-1 V analog output negative 0-1 V digital output negative	12/Black + 7/Violet + 6/Pink (**)
2	Power supply positive	1/Red + 2/Blue + 4/Grey-Pink (**)
3	Heating (*)	3/Yellow
4	RS485 A/-	9/White
5	RS485 B/+	5/Red-Blue
6	0-1 V digital output positive	8/Grey
7	Heating (*)	10/Brown
8	0-1 V analog output positive	11/Green
<b>LPSD18.3[R]</b>		
1	Power supply negative	12/Black + 7/Violet + 6/Pink (**)
2	Power supply positive	1/Red + 2/Blue + 4/Grey-Pink (**)
3	Heating (*)	3/Yellow
4	NC	9/White
5	SDI-12	5/Red-Blue
6	Volt-free contact output	8/Grey
7	Heating (*)	10/Brown
8	Volt-free contact output	11/Green

(\*) The connection of the heating is not polarized; the two wires can be reversed.

(\*\*) Wires shorted on the connector pin.



**Fig. 4.9: RS485 connection**

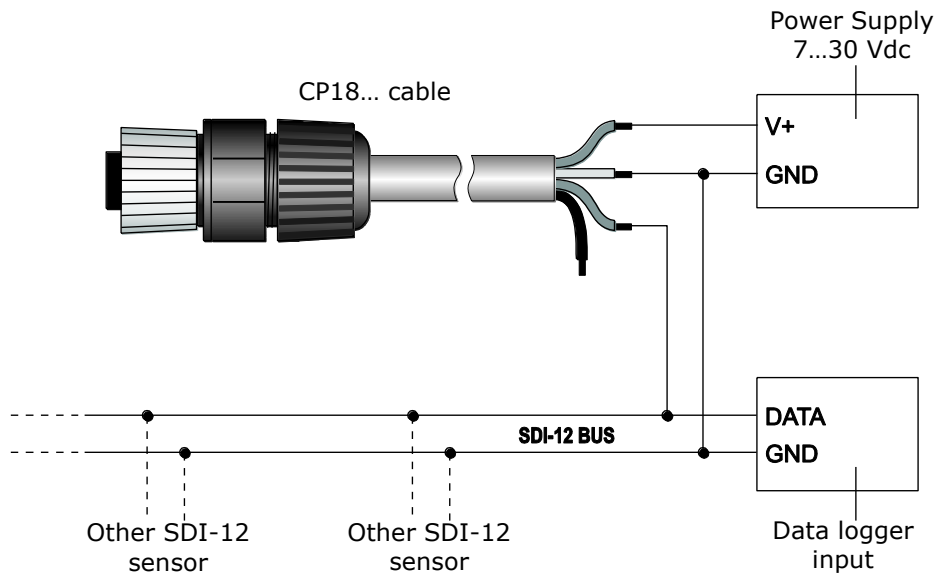

**Fig. 4.10: SDI-12 connection**

## 5 RS485 Modbus-RTU output

**LP SD18.1[R]** and **LP SD18.2[R]** are equipped with a RS485 Modbus-RTU output.

**The Modbus-RTU protocol is active after 5 seconds from power on.**

Before connecting the sensor to the RS485 network, an address must be assigned and the communication parameters must be set, if different from the factory preset.

### 5.1 Setting the communication parameters

Connect the sensor to the PC by using the supplied 8-pole M12 free connector or the optional **CP18...** cable and a RS485/USB or RS485/RS232 converter. If a RS485/USB converter is used, it is necessary to install the related USB drivers in the PC.

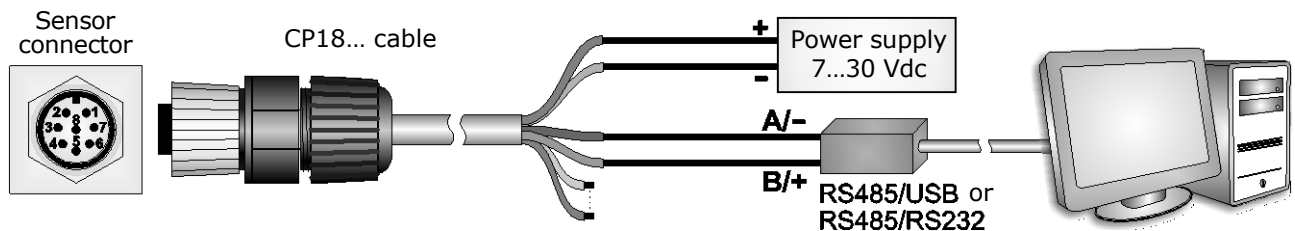

**Fig. 5.1: connection to PC**

#### Procedure:

1. Start with the sensor not powered.
2. In the PC, start a serial communication program. Set the Baud Rate to 57600 and set the communication parameters as follows (the sensor is connected to a COM type port):

Data Bits: 8  
Parity: None  
Stop Bits: 2

In the program, set the COM port number to which the sensor will be connected.

3. Switch the sensor on.
4. Wait until the sensor transmits the **&** character, then send (within 5 seconds from the sensor power on) the **@** command and press **Enter**.

*Note:* if the sensor does not receive the **@** command within 5 seconds from power on, the RS485 MODBUS mode is automatically activated. In such a case, it is necessary to switch off and on again the sensor.

5. Send the command **CAL USER ON**.

*Note:* the command CAL USER ON is disabled after 5 minutes of inactivity.

6. Send the serial commands given in the following table to set the RS485 Modbus parameters:

<b>Command</b>	<b>Response</b>	<b>Description</b>
CMA <sub>nnn</sub>	&	Set address to nnn Ranging from 1 to 247 Preset on 1
CMB <sub>n</sub>	&	Set Baud Rate n=0 ⇒ 9600 n=1 ⇒ 19200 Preset on 1 ⇒ 19200
CMP <sub>n</sub>	&	Set parity and stop bits n=0 ⇒ 8N1 (no parity, 1 stop bit) n=1 ⇒ 8N2 (no parity, 2 stop bits) n=2 ⇒ 8E1 (even parity, 1 stop bit) n=3 ⇒ 8E2 (even parity, 2 stop bits) n=4 ⇒ 8O1 (odd parity, 1 stop bit) n=5 ⇒ 8O2 (odd parity, 2 stop bits) Preset on 2 ⇒ 8E1
CMW <sub>n</sub>	&	Set waiting time after transmission n=0 ⇒ Immediate reception (violates protocol) n=1 ⇒ Waiting 3.5 characters (respects protocol) Preset on 1 ⇒ Waiting 3.5 characters

7. You can check the parameters setting by sending the following serial commands:

<b>Command</b>	<b>Response</b>	<b>Description</b>
RMA	<i>Address</i>	Read address
RMB	<i>Baud Rate</i> (0,1)	Read Baud Rate 0 ⇒ 9600 1 ⇒ 19200
RMP	<i>Tx Mode</i> (0,1,2,3,4,5)	Read parity and stop bits 0 ⇒ 8N1 1 ⇒ 8N2 2 ⇒ 8E1 3 ⇒ 8E2 4 ⇒ 8O1 5 ⇒ 8O2
RMW	<i>Rx Mode</i> (0,1)	Read waiting time after transmission 0 ⇒ Immediate reception (violates protocol) 1 ⇒ Waiting 3.5 characters (respects protocol)

*Note:* it is not required to send the CAL USER ON command to read the settings.

## 5.2 Reading the measures with the Modbus-RTU protocol

Below is the list of registers.

### Input Registers

Address	Quantity	Format
0	Internal temperature °C [x10]	16-bit integer
1	Internal temperature °F [x10]	16-bit integer
2	Direct radiation (SRD, "Direct Sunshine") in W/m <sup>2</sup>	16-bit integer
3	Status register Bit0=1 ⇒ error in the measure of radiation Bit1=1 ⇒ error in the measure of temperature Bit2=1 ⇒ data memory error Bit3=1 ⇒ program memory error	16-bit integer
4	Number of seconds in the last minute with radiation higher than 120 W/m <sup>2</sup> (number between 0 and 60)	16-bit integer
5	Number of tens of seconds in the last 10 minutes with radiation ≥ 120 W/m <sup>2</sup> (number between 0 and 60: for each interval of 10 s, in the last 10 minutes, is counted a 1 if SRD ≥ 120 W/m <sup>2</sup> for at least 5 s) For a higher resolution use the register number 5.	16-bit integer
6	Status of the sun presence/absence contact 0 = SRD < 120 W/m <sup>2</sup> (open contact) 1 = SRD ≥ 120 W/m <sup>2</sup> (closed contact)	16-bit integer
7	Status of heating: 0 = off, 1 = on	16-bit integer
8	Temperature in °C [x10] below which the heating turns on	16-bit integer
9	Circular counter from 0 to 32767 of the measuring cycles. It is increased after each measurement.	16-bit integer
10	Radiation detected by sensor #1 in W/m <sup>2</sup> [x10]	16-bit integer
11	Radiation detected by sensor #2 in W/m <sup>2</sup> [x10]	16-bit integer
12	Radiation detected by sensor #3 in W/m <sup>2</sup> [x10]	16-bit integer
13	Radiation detected by sensor #4 in W/m <sup>2</sup> [x10]	16-bit integer
14	Radiation detected by sensor #5 in W/m <sup>2</sup> [x10]	16-bit integer
15	Radiation detected by sensor #6 in W/m <sup>2</sup> [x10]	16-bit integer
16	Radiation detected by sensor #7 in W/m <sup>2</sup> [x10]	16-bit integer
17	Radiation detected by sensor #8 in W/m <sup>2</sup> [x10]	16-bit integer
18	Radiation detected by sensor #9 in W/m <sup>2</sup> [x10]	16-bit integer
19	Radiation detected by sensor #10 in W/m <sup>2</sup> [x10]	16-bit integer
20	Radiation detected by sensor #11 in W/m <sup>2</sup> [x10]	16-bit integer
21	Radiation detected by sensor #12 in W/m <sup>2</sup> [x10]	16-bit integer
22	Radiation detected by sensor #13 in W/m <sup>2</sup> [x10]	16-bit integer
23	Radiation detected by sensor #14 in W/m <sup>2</sup> [x10]	16-bit integer
24	Radiation detected by sensor #15 in W/m <sup>2</sup> [x10]	16-bit integer
25	Radiation detected by sensor #16 in W/m <sup>2</sup> [x10]	16-bit integer

For the numbering of the sensors see the following figure. To identify the sensors, the reference is the square mark at the top when the sensor is installed.

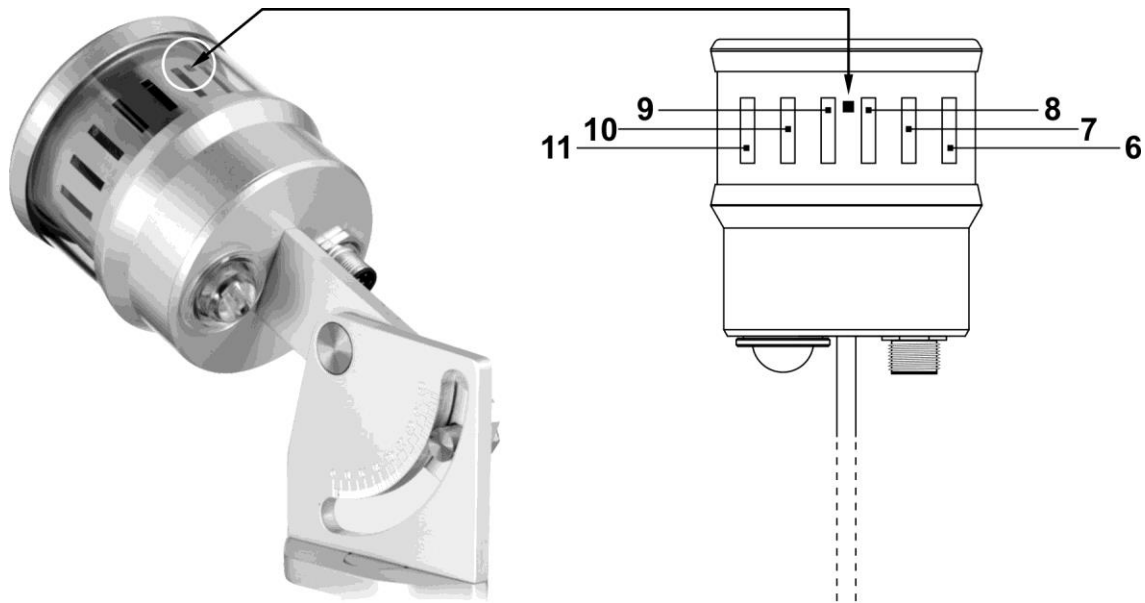

**Fig. 5.2: numbering of the sensors**

### 5.3 Change of the heating activation temperature

The temperature below which the heating turns on can be changed by writing the value in the Holding Register with address 2. The value must be set in tenths of degrees between -450 (-45.0 °C) and 700 (+70.0 °C).

**The modification of the Holding Register with address 2 changes only the value in the RAM memory, the change is therefore cancelled in case of instrument power supply failure.** To make the change permanent, write the hexadecimal value FF00 in the Coil Register with address 2.

To check if the permanent storage has been completed successfully, verify that the Holding Register with address 1 contains the value 0.

#### Coils

Address	Datum
2	Permanent storage of the heating activation temperature.

#### Holding Registers

Address	Datum	Format
0	Indicator of the correct interpretation of the last Modbus command sent. If 0, the command has been executed correctly. If 1, command execution errors occurred.	16-bit integer
1	Indicator of the correct permanent storage of heating activation temperature. If 0, the temperature has been stored correctly. If 1, storage errors occurred.	16-bit integer
2	Heating activation temperature in °C [x10].	16-bit integer

**CHECK OF THE CORRECT INTERPRETATION OF THE MODBUS COMMANDS:** in order to check if the last Modbus command sent to the instrument has been interpreted correctly, verify that the Holding Register with address 0 contains the value 0.

## 6 SDI-12 output

**LPSD18.3** is equipped with an SDI-12 communication interface compliant with the version 1.3 of the protocol.

The protocol communication parameters are: Baud rate = 1200. Data bits = 7, Parity = Even, Stop bits = 1.

The communication with the instrument is performed by sending a command in the following form:

**<Address><Command>!**

with <Address> = address of the instrument the command is sent to  
<Command> = type of operation requested to the instrument

The instrument reply is as follows:

**<Address><Data><CR><LF>**

with <Address> = address of the instrument which replies  
<Data> = information sent by the instrument  
<CR> = ASCII character *Carriage Return*  
<LF> = ASCII character *Line Feed*

The sensors come with a factory address preset to 0. The address can be modified by using the proper SDI-12 command reported in the following table.

The following table reports the SDI-12 commands available. For consistency with SDI-12 standard documentation, the instrument address is indicated in the table with the letter **a**.

### SDI-12 Commands

Command	Instrument reply	Description
<b>a!</b>	a<CR><LF>	Verifies the presence of the instrument.
<b>aI!</b>	allccccccmmmmmmvvvsssssss<CR><LF> with: a = address of the instrument (1 character) ll = SDI-12 compliant version (2 characters) ccccccc = manufacturer (8 characters) mmmmm = instrument model (6 characters) vvv = firmware version (3 characters) sssssss = serial number (8 characters)  ⇒ Example of response: 013DeltaOhmLPSD1810013201518 with: 0 = instrument address 13 = SDI-12 version 1.3 compliant DeltaOhm = manufacturer's name LPSD18 = instrument model 100 = firmware version A.0.0 13201518 = serial number	Requests for information from the instrument.



Command	Instrument reply	Description
<b>aAb!</b> Where: b =new address	b<CR><LF>  Note: if the b character is not an acceptable address, the instrument responds with a instead of b.	Modification of the instrument address.
<b>?!</b>	a<CR><LF>	Request of the address of the instrument. If more than one sensor is connected to the bus, a conflict occurs.
<b>TYPE M (START MEASUREMENT) AND TYPE C (START CONCURRENT MEASUREMENT) COMMANDS</b>		
<b>Insolation status</b>		
<b>aM!</b> <b>aC!</b>	atttn<CR><LF> with: ttt = number of seconds necessary for the instrument to make the measure available (3 characters) n = number of detected variables (1 character for aM!, 2 characters for aC!) Note: ttt = 000 means datum immediately available.	Request of detection of the insolation status (presence or absence of sun).
<b>aD0!</b>	a+x<CR><LF> with: x = 0 if SRD < 120 W/m <sup>2</sup> , x = 1 if SRD ≥ 120 W/m <sup>2</sup> ⇒ Example of response: 0+0 The instrument with address 0 measures SRD < 120 W/m <sup>2</sup>	Reads the status of insolation (presence or absence of sun).
<b>Direct Solar Radiation</b>		
<b>aM1!</b> <b>aC1!</b>	atttn<CR><LF> with: ttt = number of seconds necessary for the instrument to make the measure available (3 characters) n = number of detected variables (1 character for aM1!, 2 characters for aC1!) Note: ttt = 000 means datum immediately available.	Request for performing the measurement of direct solar radiation (SRD) in W/m <sup>2</sup> .
<b>aD0!</b>	a+rddd<CR><LF> with: rddd = SRD with resolution 1 W/m <sup>2</sup> ⇒ Example of response: 0+0135 The instrument with address 0 measures SRD = 135 W/m <sup>2</sup>	Reads the measurement of direct solar radiation (SRD) in W/m <sup>2</sup> .

Command	Instrument reply	Description
<b>State and duration of sunshine</b>		
<b>aM2!</b> <b>aC2!</b>	attn<CR><LF> with: ttt = number of seconds necessary for the instrument to make the measure available (3 characters) n = number of detected variables (1 character for aM2!, 2 characters for aC2!) Note: ttt = 000 means datum immediately available.	Request for detecting status and lasting of insolation.
<b>aD0!</b>	a+x+mm+dd+nnnn<CR><LF> with: x = 0 if SRD < 120 W/m <sup>2</sup> , x = 1 if SRD ≥ 120 W/m <sup>2</sup> mm = number of seconds in the last minute with x=1 dd = number of tens of seconds in the last 10 minutes with x=1 (dd=0...60: for each interval of 10 s, a 1 is added if x=1 for at least 5 s) nnnn = circular counter of the measuring cycles number. ⇒ Example of response: 0+1+25+12+00048 The instrument with address 0 measures x=1, in the last minute there have been 25 s with x=1, in the last 10 min there have been from 60 to 120 s with x=1, 48 measuring cycles have elapsed since the counter reset.	Reads status and lasting of isolation.
<b>Internal temperature and heating status</b>		
<b>aM3!</b> <b>aC3!</b>	attn<CR><LF> with: ttt = number of seconds necessary for the instrument to make the measure available (3 characters) n = number of detected variables (1 character for aM3!, 2 characters for aC3!) Note: ttt = 000 means datum immediately available.	Request of detecting the internal temperature and the heating status.
<b>aD0!</b>	a+nn.d+n<CR><LF> with: nn.d = internal temperature in °C n = 0 when heating OFF, n = 1 when heating ON ⇒ Example of response: 0+15.3+0 the instrument with address 0 measures 15.3 °C of internal heating and the heater is switched off.	Reads the internal temperature and the heating status.
<b>TYPE R (CONTINUOUS MEASUREMENTS) COMMANDS</b>		
<b>aR0!</b>	a+x<CR><LF> with: x = 0 if SRD < 120 W/m <sup>2</sup> , x = 1 if SRD ≥ 120 W/m <sup>2</sup>	Reads the status of insolation (presence of absence of sun).
<b>aR1!</b>	a+rrrr<CR><LF> with: rrrr = SRD with resolution 1 W/m <sup>2</sup>	Reads the measure of the direct solar radiation (SRD) in W/m <sup>2</sup>

Command	Instrument reply	Description
<b>aR2!</b>	a+x+mm+dd+nnnnn<CR><LF> with: x = 0 if SRD < 120 W/m <sup>2</sup> , x = 1 if SRD ≥ 120 W/m <sup>2</sup> mm = number of seconds in the last minute with x=1 dd = number of tens of seconds in the last 10 minutes with x=1 (dd=0...60: for each interval of 10 s, a 1 is added if x=1 for at least 5 s) nnnnn =circular counter of the measuring cycles number	Reads status and lasting of insolation.
<b>aR3!</b>	a+nn.d+n<CR><LF> with:nn.d = internal temperature in °C n = 0 when heating OFF, n = 1 when heating ON	Reads internal temperature and status of heating

In addition to the above-mentioned commands, the sensor also implements the corresponding commands with CRC, that require to add a 3-character CRC code at the end of the reply before <CR><LF>. The format of these commands is obtained from the previous by adding the letter C: aMC!, aMC1!, aMC2!, aMC3!, aCC!, aCC1!, aCC2!, aCC3!.

For more information about the SDI-12 protocol, visit the website "[www.sdi-12.org](http://www.sdi-12.org)".

## 7 Maintenance

In order to grant measurements high accuracy, it is important to keep the protective glass clean.

You can wash it using water and microfiber cloths for lens. If necessary, use pure ETHYL alcohol. After using alcohol, clean again the protective glass with water only and dry it thoroughly.

In order to minimize the condensation, the sensor is provided with a heating element and a cartridge containing dessicant material (silica-gel). The efficiency of the silica-gel crystals decreases over time while absorbing humidity. Silica-gel crystals are efficient when their color is **yellow**, while they turn **white/translucent** as soon as they lose their efficiency. Read instructions on chapter [Errore. L'origine riferimento non è stata trovata.](#) about how to replace the silica-gel crystals. Silica-gel typical lifetime goes from 2 to 6 months depending on the environment where the sensors works.

## 8 Safety instructions

The instrument proper operation and operating safety can be ensured only in the climatic conditions specified in this manual and if all standard safety measures as well as the specific measures described in this manual are followed.

Do not use the instruments in places where there are:

- Corrosive or flammable gases.
- Direct vibrations or shocks to the instrument.
- High-intensity electromagnetic fields, static electricity.

### **User obligations**

The instrument operator shall follow the directives and regulations below that refer to the treatment of dangerous materials:

- EU directives on workplace safety.
- National law regulations on workplace safety.
- Accident prevention regulations.

## 9 Accessories ordering codes

<b>CP18...</b>	Cable with 8-pole M12 connector on one end, open wires on the other end. Length 5 m (CP18.5) or 10 m (CP18.10).
<b>LPSD18.O</b>	Base for installation of the sunshine duration sensor on a horizontal plane. Two adjustable feet and one fixed foot. Allows the inclination of the sensor up to 80° (with graduated scale) from the vertical, to suit the position of the sun to the latitude of the place of installation.
<b>LPSD18.VK</b>	Support for installation of the sunshine duration sensor on a mast Ø 40 mm. Allows the inclination of the sensor up to 80° (with graduated scale) from the vertical, to suit the position of the sun to the latitude of the place of installation. It allows the rotation of the sensor on a horizontal plane.
<b>LPSG</b>	Cartridge for containing crystals of silica gel with O-ring.
<b>LPG</b>	Pack of 5 cartridges of the silica-gel.

## **WARRANTY**

The manufacturer is required to respond to the "factory warranty" only in those cases provided by Legislative Decree 6 September 2005 - n. 206. Each instrument is sold after rigorous inspections; if any manufacturing defect is found, it is necessary to contact the distributor where the instrument was purchased from. During the warranty period (24 months from the date of invoice) any manufacturing defects found will be repaired free of charge. Misuse, wear, neglect, lack or inefficient maintenance as well as theft and damage during transport are excluded. Warranty does not apply if changes, tampering or unauthorized repairs are made on the product. Solutions, probes, electrodes and microphones are not guaranteed as the improper use, even for a few minutes, may cause irreparable damages.

The manufacturer repairs the products that show defects of construction in accordance with the terms and conditions of warranty included in the manual of the product. For any dispute, the competent court is the Court of Padua. The Italian law and the "Convention on Contracts for the International Sales of Goods" apply.

## **TECHNICAL INFORMATION**

The quality level of our instruments is the result of the continuous product development. This may lead to differences between the information reported in the manual and the instrument you have purchased.

We reserve the right to change technical specifications and dimensions to fit the product requirements without prior notice.

## **DISPOSAL INFORMATION**

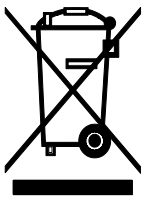

Electrical and electronic equipment marked with specific symbol in compliance with 2012/19/EU Directive must be disposed of separately from household waste. European users can hand them over to the dealer or to the manufacturer when purchasing a new electrical and electronic equipment, or to a WEEE collection point designated by local authorities. Illegal disposal is punished by law.

Disposing of electrical and electronic equipment separately from normal waste helps to preserve natural resources and allows materials to be recycled in an environmentally friendly way without risks to human health.



[senseca.com](http://senseca.com)



Senseca Italy S.r.l.  
Via Marconi, 5  
35030 Selvazzano Dentro (PD)  
ITALY  
[info@senseca.com](mailto:info@senseca.com)

