

# Operating Instructions Differential Pressure Transducer PS27



halstrup-walcher GmbH

Stegener Straße 10  
79199 Kirchzarten/Germany

Phone: +49 (0) 76 61/39 63-0  
Fax: +49 (0) 76 61/39 63-99

E-mail: [info@halstrup-walcher.com](mailto:info@halstrup-walcher.com)  
Internet: [www.halstrup-walcher.com](http://www.halstrup-walcher.com)

## Contents

1. Safety Instructions .....	4
1.1 Use for Intended Purpose Only .....	4
1.2 Transport, Installation, Connection and Startup .....	4
1.3 Malfunctions, Maintenance, Repairs, Disposal.....	4
1.4 Symbols.....	5
2. Description of the Transducer .....	6
3. Startup.....	6
3.1 Functional Description .....	6
3.2 Connections for Four-Wire version (standard) in the device:.....	7
3.3 Connections for Two-Wire System (Option): .....	8
4. Resetting Offset .....	8
5. Configuring the Output Signal .....	9
6. Setting the Measuring Range (Optional) .....	9
7. Display (Option) .....	10
8. Setting the Relay Operating Point (Option) .....	10
9. In case of Malfunctions .....	10
10. Specifications.....	10
11. Dimensional Drawing .....	12
12. Certificate of Conformity.....	13

## Significance of the Operating Instructions

These operating instructions go into the function and handling of the PS27 differential pressure transducer

Use at variance to the purpose of the transducer and its incorrect operation may result in risks arising for both people and assets. That is why each and every person charged with handling the transducer must be instructed in its use and is to be aware of the dangers. Close attention must be given to these operating instructions and, in particular, to the associated safety instructions. **Do contact the manufacturer should you not understand all the sections.**

Be heedful of the operating instructions:

- They must be readily available during the entire service life of the transducer.
- They must be passed on to the succeeding personnel charged with operations.
- Any additions coming from the manufacturer must be inserted.

The manufacturer reserves the right to refine this type of appliance without having to document this fact in each particular instance. The manufacturer is more than willing to provide you with information on the updated nature of these operating instructions.

## Conformity

This transducer conforms with the present stage reached in technical engineering. It complies with the statutory requirements of the EC directives. This is documented from the CE mark being affixed.



© 2015, 2017, 2018, 2021

The copyright to these operating instructions rests with the manufacturer. They include specifications, instructions and drawings on the function and handling of the transducer. Neither in their entirety nor in part are they to be duplicated or made available to third parties.

## 1. Safety Instructions

### 1.1 Use for Intended Purpose Only

The PS27 differential pressure transducer registers both differential pressure and positive/negative gauge pressure.

The operational requirements on the rating plate and in the "Specifications" chapter - and the safe supply voltage in particular - must be kept to.

The transducer is only to be handled in conformity with these operating instructions. No modifications to the transducer are permitted. The manufacturer is not liable for damage arising from any incorrect use or one at variance to the intended purpose. Claims to warranty in such an instance would be forfeited.

### 1.2 Transport, Installation, Connection and Startup

Do not block the pressure inlets on the transducer being moved! Changes in barometric pressure may damage transducers with low measuring ranges.

Only qualified personnel are to assemble the appliance and see to its electrical connections. They must be instructed as such and be assigned by the plant operator.

Only instructed persons as assigned by the plant operator are to operate the transducer.

Do not perform any functional test involving compressed or breathable air. This would otherwise damage those transducers with low measuring ranges.

Measurement errors may occur should the appliance not be protected from sunlight.

Specific safety instructions are given in the individual chapters.

### 1.3 Malfunctions, Maintenance, Repairs, Disposal

Malfunctions which cannot be put right as specified in Chapter 8 and damage at the appliance itself must be immediately reported to the qualified personnel with responsibility for the electrical connections.

The appliance must be taken out of service by the qualified personnel responsible until the malfunction has been put right and also secured against being unintentionally used.

**Always switch off the power to the appliance before it is opened!**

The appliance does not need any maintenance.

Only the manufacturer is to carry out repairs.

The electrical components of the transducer contain both environmentally hazardous materials and materials that can be reused. That is why the appliance is to be recycled once it is finally immobilized. The environment directives on this from the country in question must be followed.

## 1.4 Symbols

The symbols below in these operating instructions point to the risks, which could arise in handling the equipment:



**WARNING!** It points to a hazard possibly extending from injures through to death should the instructions not be followed.



**CAUTION!** It points to a hazard which could cause considerable damage should the instructions not be followed.



**INFORMATION!** This indicates information, which is vital for proper appliance operations.

## 2. Description of the Transducer

Type PS27 differential pressure transducers are pneumatic/electrical sensors for pressure testing (positive/negative gauge pressure and differential pressure) purposes. They are typically used in air-conditioning and ventilation technology e.g. pressure testing in ventilation ducts. The transducer's core is a piezoresistive pressure transducer.

## 3. Startup

### 3.1 Functional Description

PS27 pressure transducers are of the precision type and despite their sturdiness they should still be treated with care. Installation right next to heat and radiation sources e.g. radiators should be avoided as this may lead to measurement errors arising. Ideally the appliance should be vertically mounted on a wall not subject to any vibrations. To stop any condensed water entering the measurement cell, the transducer together with the hose connections for positive gauge pressure + and negative gauge pressure - should be pointing downwards.

The right pressure sign must be used in keeping with the following table when connecting the pressure to the transducer:

Type of pressure	Connect pressure to	Example
pos. gauge pressure	+ input	0...1 kPa
neg. gauge pressure	- input	0...- 500 Pa
Differential pressure	Higher pressure at + input lower pressure at - input	0...125 Pa e.g via a differential pressure producer (e.g. measuring orifice)
Symmetrical pressure ranges	+ input	$\pm$ 200 Pa
Asymmetrical pressure ranges	Input of the larger pressure range	-300 Pa...+ 1 kPa (here connect to + input)

### 3.2 Connections for Four-Wire version (standard) in the device:

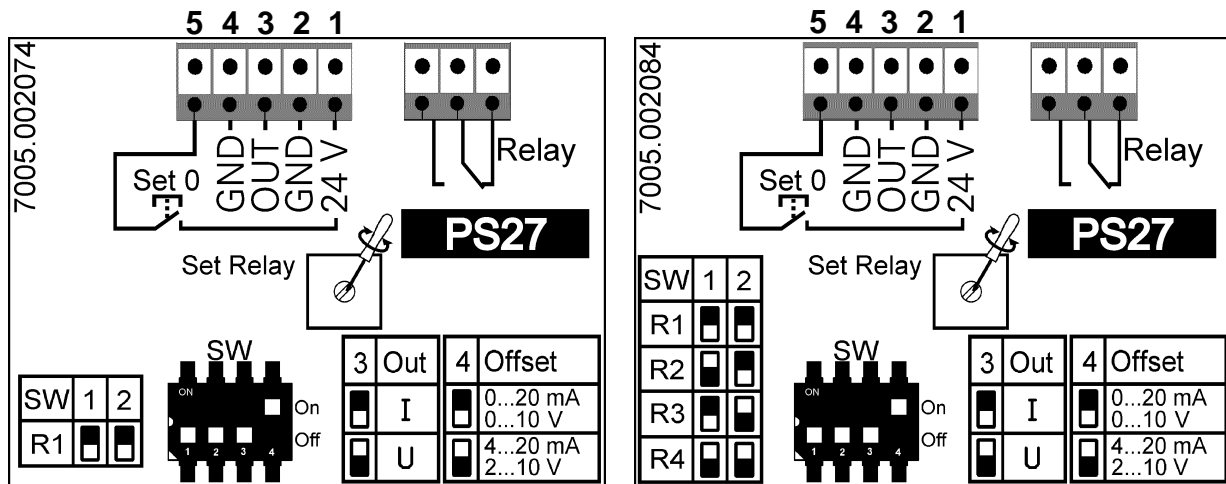

One measurement range

Four measurement ranges



Note the prescribed supply voltage (see rating plate). Also follow the connection diagram on the appliance cover / circuit board mount.

ST4 Pin	Connection name	Meaning
1	24V	Power supply input - 24VAC/DC
2	GND	Ground for power supply
3	OUT	Voltage or current output
4	GND	Ground for output signal
5	SET 0	Zero-point input (+24V zero-point is active)

The transducer outputs are protected from short circuits. The DC-supplied appliances are protected from reverse polarity of the supply voltage.

### 3.3 Connections for Two-Wire System (Option):

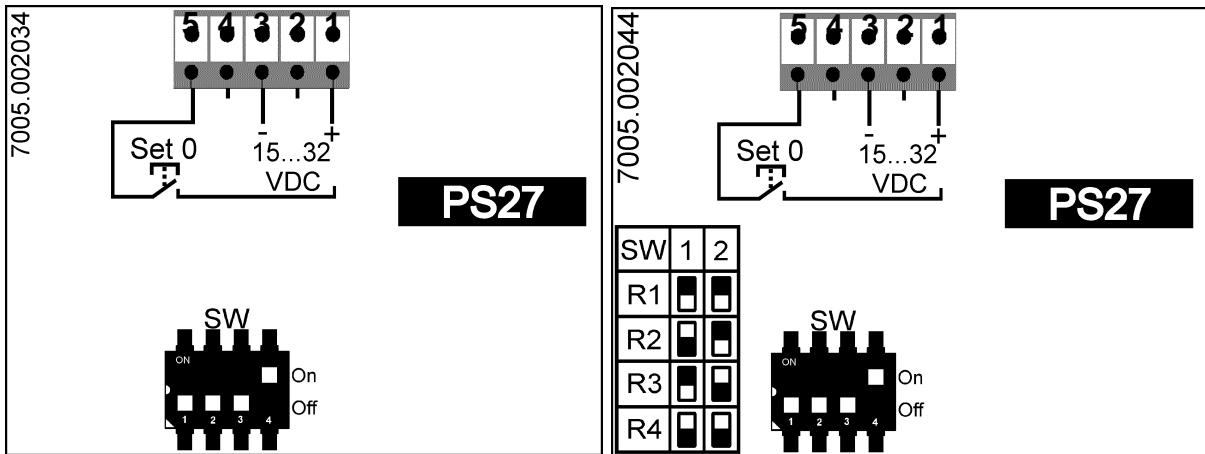

One measurement range

Four measurement ranges

ST4 Pin	Connection name	Meaning
1	24V	+terminal 15-32VDC
2	GND	Not used
3	OUT	-terminal
4	GND	Not used
5	SET 0	Zero-point input

## 4. Resetting Offset



After starting the pressure transducer, give it some 15 minutes to warm up. During this time the output signal may be unstable.

Zero-point calibration of the appliance is only effected via the input assigned for this purpose. **The user must ensure that the appliance is not subjected to any pressure during the calibration process as this might lead to a wrong offset value which, in turn, would result in a wrong output signal.** The 24V input makes it possible to activate a 3/2 directional control valve with the same signal, which switches the PS27's pressure inputs at zero pressure during the zero calibration process. In this case the zero point calibration signal must be applied until there is no doubt that the pressure has fallen to zero.



While Resetting Offset is in progress, the power supply must not be switched off. This might result in a loss of the device setting and may leave the PS27 unusable.



## 5. Configuring the Output Signal

The user can configure the PS27's output signal. This can be done in various ways

Output	SW Pos 3	SW Pos 4	Comments
0...10V	on	off	$R_{Load} > 50k \Omega$
2...10V	on	on	$R_{Load} > 50k \Omega$
0...20mA	off	off	max. load 500 $\Omega$
4...20mA	off	on	max. load 500 $\Omega$

The two-wire model must be configured by the manufacturer.

## 6. Setting the Measuring Range (Optional)

The transducer with 4 measuring ranges can be adapted to the measuring assignment in question. The teaching of 4 measuring ranges into the appliance has been undertaken by the manufacturer. The switches 1 and 2 of SW can be used to select the measuring range in question before the transducer is switched on.

SW Pos 1	SW Pos 2	Measuring range
off	off	1
on	off	2
off	on	3
on	on	4

The limiting values of the measuring ranges are noted on the nameplate of the PS27. Display-optional appliances indicate the limiting value of the selected measuring range for 1.5 seconds after being switched-on. The appliance should be re-zeroed following any measuring range change-over. This is because the amplification change-over may produce offset voltages.

Four-wire:

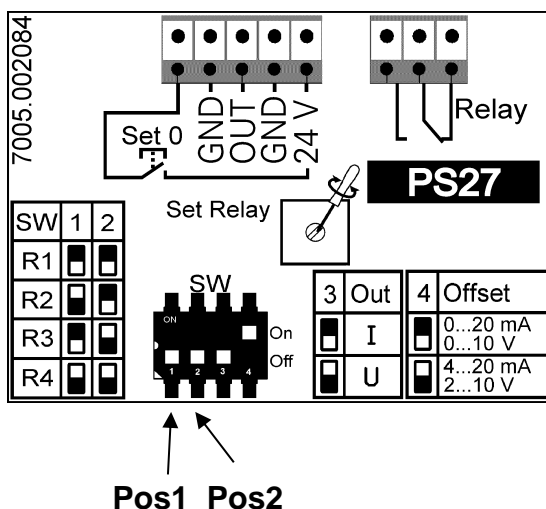

Two-wire:

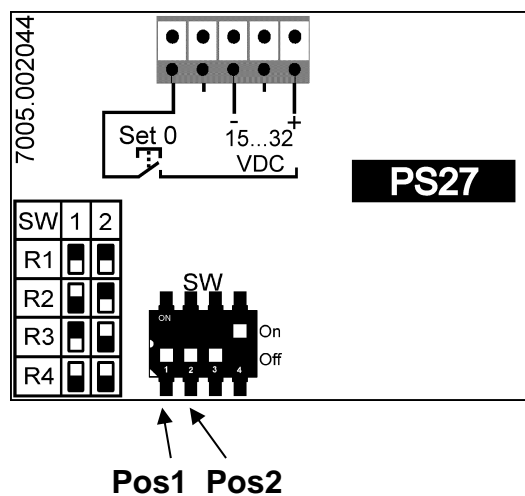

## 7. Display (Option)

To show up the readings, the PS27 can also be fitted out with a display. The readings will be shown in either Pa or kPa depending on the limiting value of the measuring range. The number of the measuring range selected is always shown on the bottom line of the display.

On switching on a display-equipped appliance, the first thing shown is the PS27 programme version followed by a 1.5 second screening of the limiting value of the selected measuring range and then the actual readings.

## 8. Setting the Relay Operating Point (Option)

The relay operating point can be adjusted with the aid of the potentiometer P2.1 (Set Relay). Adjustment is easiest when the desired switching pressure is applied and the potentiometer set so that the relay is just triggered.

**Please note: The relay is connected to the sensor's output so that any adjusted time delay will also cause a delay in relay triggering.**

## 9. In case of Malfunctions

Fault description	Possible cause	Corrective action
No output signal	<ul style="list-style-type: none"> <li>• Supply voltage is not connected</li> <li>• Incorrect supply voltage connected</li> <li>• Defective input protection diode</li> </ul> Only for DC power: <ul style="list-style-type: none"> <li>• defective reverse polarity diode</li> </ul>	<ul style="list-style-type: none"> <li>• Connect correct supply voltage</li> <li>• Connect correct supply voltage (see rating plate)</li> <li>• Send the appliance to the manufacturer for repairs</li> <li>• Send the appliance to the manufacturer for repairs</li> </ul>
Output signal is constant despite change in pressure	<ul style="list-style-type: none"> <li>• Defective output protection diode</li> <li>• Pressure ports reversed</li> </ul>	<ul style="list-style-type: none"> <li>• Send the appliance to the manufacturer for repairs</li> <li>• Connect the pressure as described in "3. Installation"</li> </ul>
Output signal incorrect	<ul style="list-style-type: none"> <li>• Faulty pressure sensor</li> <li>• Zeroing with pressure applied</li> </ul> For current output: <ul style="list-style-type: none"> <li>• load too high</li> </ul> For voltage output <ul style="list-style-type: none"> <li>• Load resistance too low</li> </ul>	<ul style="list-style-type: none"> <li>• Send the appliance to the manufacturer for repairs</li> <li>• Renewed zeroing without pressure</li> <li>• Note maximum 500 <math>\Omega</math> load</li> <li>• Note minimum 50 k load resistance <math>\Omega</math> (see "7 Specifications")</li> </ul>

## 10. Specifications

Accuracy:	1.0 % of the measuring range limiting value
t.c. offset:	+/- 0.1 %/°C
t.c. span:	+/- 0.1 %/°C
Measuring ranges:	+/-2.0kPa (+/-100 Pa...2,0 kPa) +/-10 kPa (+/-2,5 kPa... 10 kPa) +/-100 kPa (+/-20 kPa...100 kPa) As an option, the customer can use a DIP-switch to select 4 pre-set measuring ranges
Response time:	25 ms, 1s, 4s,10s(time to reach 63% of actual value)
Pressure ports:	Nominal 4 or 6 mm width for hose
Output signals:	0/2...10 V or. ( $R_L > 50 \text{ kOhm}$ ) 0/4...20 mA ( $R_L \leq 500 \text{ Ohm}$ ) 4...20 mA (two-wire 17...32 V, $R_L \leq 500 \text{ Ohm}$ )
Switching contact (optional):	max. 230 VAC, 6 A; min. 500 mW
Display (optional):	3½-digit LCD
Overload range:	Range +/-2,0kPa : 10 kPa Range +/-10 kPa : 200kPa Range +/-100 kPa : 500kPa
Storage temperature:	-20°C...+70°C
Working temperature:	-20°C...+60°C, with Display 0°C...50°C
Supply voltage:	24 VDC/VAC +/-10 % (no galvanic isolation) 15 ... 32 VDC (two-wire) (no relay output)
Power consumption:	approx. 1 W
Operating position:	vertical preference
Housing:	see drawing
Protection class:	IP 65
Installation:	The appliance can be installed either on a top-hat rail or on a wall with fastening holes
Testing:	EN 61000-4-2, EN 61000-4-3...-6, EN 61000-4-11, EN V50204

## 11. Dimensional Drawing

no LCD

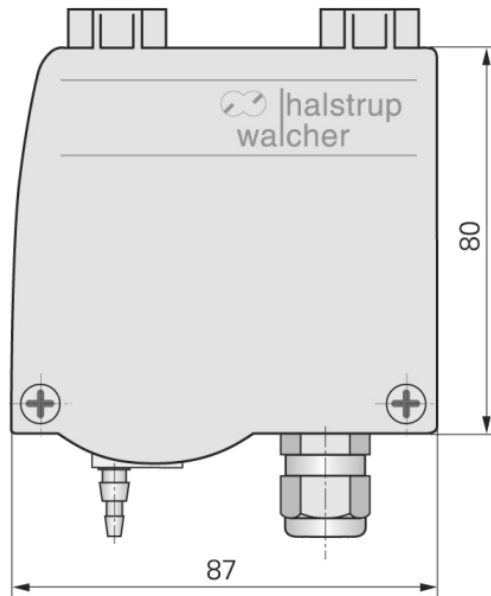

with LCD

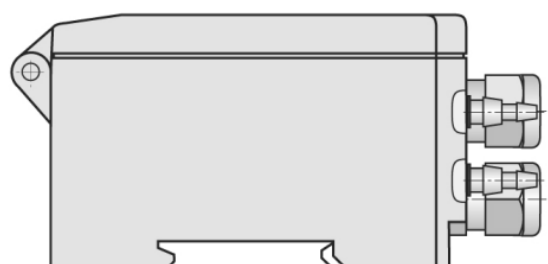
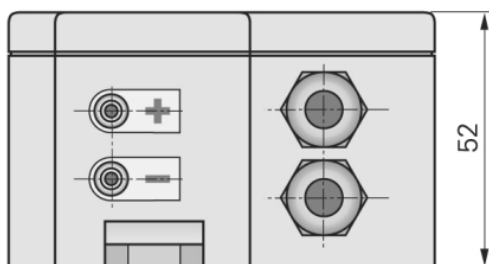
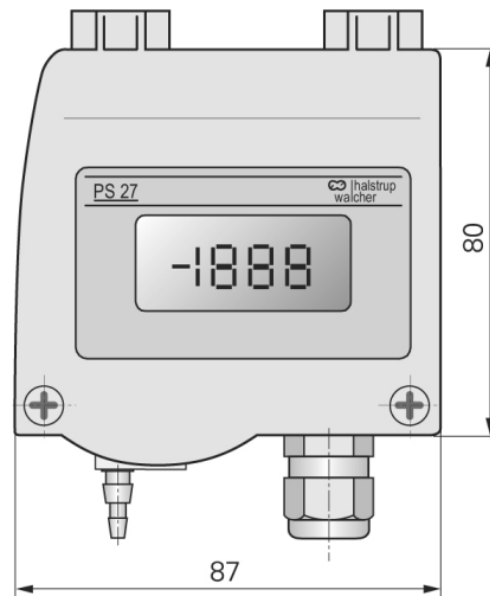

For additional specifications and dimension drawings, please visit our website at

<http://www.halstrup-walcher.de/en/products/measurement-technology/index.php>

## 12. Certificate of Conformity



Die Lösung liegt im Detail

**EG-Konformitätserklärung** im Sinne der  
EG- Richtlinie 2014/30/EU, EMV Richtlinie und  
2006/95/EG, Niederspannungsrichtlinie

**Certificate of Conformity** based on the  
European Standard 2014/30/EU, and 2006/95/EG

Der Hersteller  
The manufacturer

**halstrup-walcher GmbH  
Stegener Straße 10  
79199 Kirchzarten  
Deutschland**

erklärt, dass die Bauart des Produktes  
declares, that the construction of instrument type

**Differenzdruck Messumformer Typ PS27  
Differential Pressure Transmitter Type PS27**

entwickelt, konstruiert und gefertigt ist in Übereinstimmung mit den EG – Richtlinien  
is developed, designed and manufactured in accordance with the EC Directives.

EN 61000-6-2 : 2005  
EN 61000-6-4 : 2011  
EN 61010-1 : 2011

abgegeben durch / stated by:

Sura, Christian  
(Nachname, Vorname / Surname, first name)

Geschäftsführer, Managing Director  
(Stellung im Betrieb des Herstellers / Position )

Kirchzarten, 03. 05. 2018  
(Ort, Datum / City, Date)

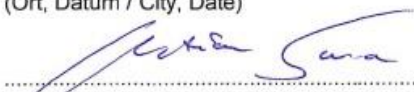
  
(Rechtsgültige Unterschrift/ Signature)