

PM[B]senseCR

PM / CO₂ transmitter

ENGLISH

TABLE OF CONTENTS

1	INTRODUCTION	3
2	TECHNICAL SPECIFICATIONS	4
3	INSTALLATION	5
	3.1 ELECTRICAL CONNECTIONS	5
4	CONFIGURATION AND MEASUREMENT	8
5	PROPRIETARY PROTOCOL	9
6	MODBUS-RTU PROTOCOL	15
7	SAFETY INSTRUCTIONS	20
8	ACCESSORIES ORDERING CODES	21

1 INTRODUCTION

PMsenseCR is a Particulate Matter transmitter suitable for monitoring clean rooms and controlled atmosphere environments as required by the **ISO 14644** standard.

The dust particles concentration is measured using the laser scattering principle and the number of particles per cubic meter (pcs/m³) is provided. The transmitter discriminates particles of size:

- > 0.3 µm
- > 0.5 µm
- > 1 µm
- > 2.5 µm
- > 5 µm

An optional CO₂ sensor can be integrated in the transmitter (**PMBsenseCR**).

The transmitter has a digital RS485 output with MODBUS-RTU or ASCII proprietary protocol. A version with two additional 4...20 mA (0...10 V **on request when ordering**) analog outputs is available. The two analog outputs can be independently associated with any of the measured parameters.

The measuring circuit of the transmitter can be operated in continuous mode (default operating mode) or, in order to extend the PM sensor lifetime, at cyclic intervals. The measuring cycle interval is user configurable.

The transmitter is maintenance-free and has fast response, high sensitivity, excellent stability and long operating life.

Models

Model	Measurement		Output	
	Particulate Matter	CO ₂	RS485	Analog (*)
PMsenseCR-M	√		√	
PMsenseCR-A	√		√	√
PMBsenseCR-M	√	√	√	
PMBsenseCR-A	√	√	√	√

(*) Two analog outputs, standard 0/4...20 mA, on request 0...10 V.

2 TECHNICAL SPECIFICATIONS

Particulate Matter	
Measuring principle	Laser scattering
Measured pollutants	N° of particles/m ³ with size > 0.3 µm N° of particles/m ³ with size > 0.5 µm N° of particles/m ³ with size > 1 µm N° of particles/m ³ with size > 2.5 µm N° of particles/m ³ with size > 5 µm
Measuring range	< 5 x 10 ⁷ pcs/m ³ (loss of linearity above this threshold)
Particle size detection range	Ø 0.3...10 µm
Linearity error	< 5%
Repeatability	< 3% for N° of particles/m ³ with size > 0.3 µm and > 0.5 µm < 5% for N° of particles/m ³ with size > 1 µm < 10% for N° of particles/m ³ with size > 2.5 µm < 15% for N° of particles/m ³ with size > 5 µm
Sensor warm up time	15 s
Sensor lifetime	> 10,000 hours in continuous operating mode (default, 1 meas./s) 5 years approx. in 5 minutes cyclic operating mode
CO₂ (only PMBsenseCR...)	
Measuring principle	Double wavelength NDIR
Measuring range	0...5000 ppm
Accuracy	±(50 ppm+3% of measurement) @ 25 °C and 1013 hPa
Response time	< 120 s (air speed= 2 m/s)
Long-term stability	5% of measurement / 5 years
Temperature drift	1 ppm/°C
General specifications	
Output	RS485 with Modbus-RTU or ASCII proprietary protocol Only PM[B]senseCR-A : 2 x analog 4...20 mA (R _{Lmax} = 500 Ω); on request 2 x 0...10 V (R _{Lmin} = 10 kΩ)
Power supply	7...30 Vdc (15...30 Vdc for 0...10 V analog outputs)
Power consumption	25 mA @ 24 Vdc during measurement 4 mA in stand-by (only for cyclic operating mode) The indicated consumption does not include the consumption due to the analog outputs
Connection	M12 8-pole circular connector
Operating conditions	-20...+70 °C / 0...95 %RH / 500...1500 hPa
Housing material	Polycarbonate
Protection degree	Housing equipped with a rain-proof and UV resistant inlet air filter – IP 53
Dimensions	120 x 94 x 71 (excluding M12 connector)
Weight	330 g

3 INSTALLATION

The transmitter is equipped with a bracket with U-bolt for the fixing to a $\varnothing 40\text{...}50$ mm mast. It can be fixed to a wall using the bracket only, by removing the U-bolt.

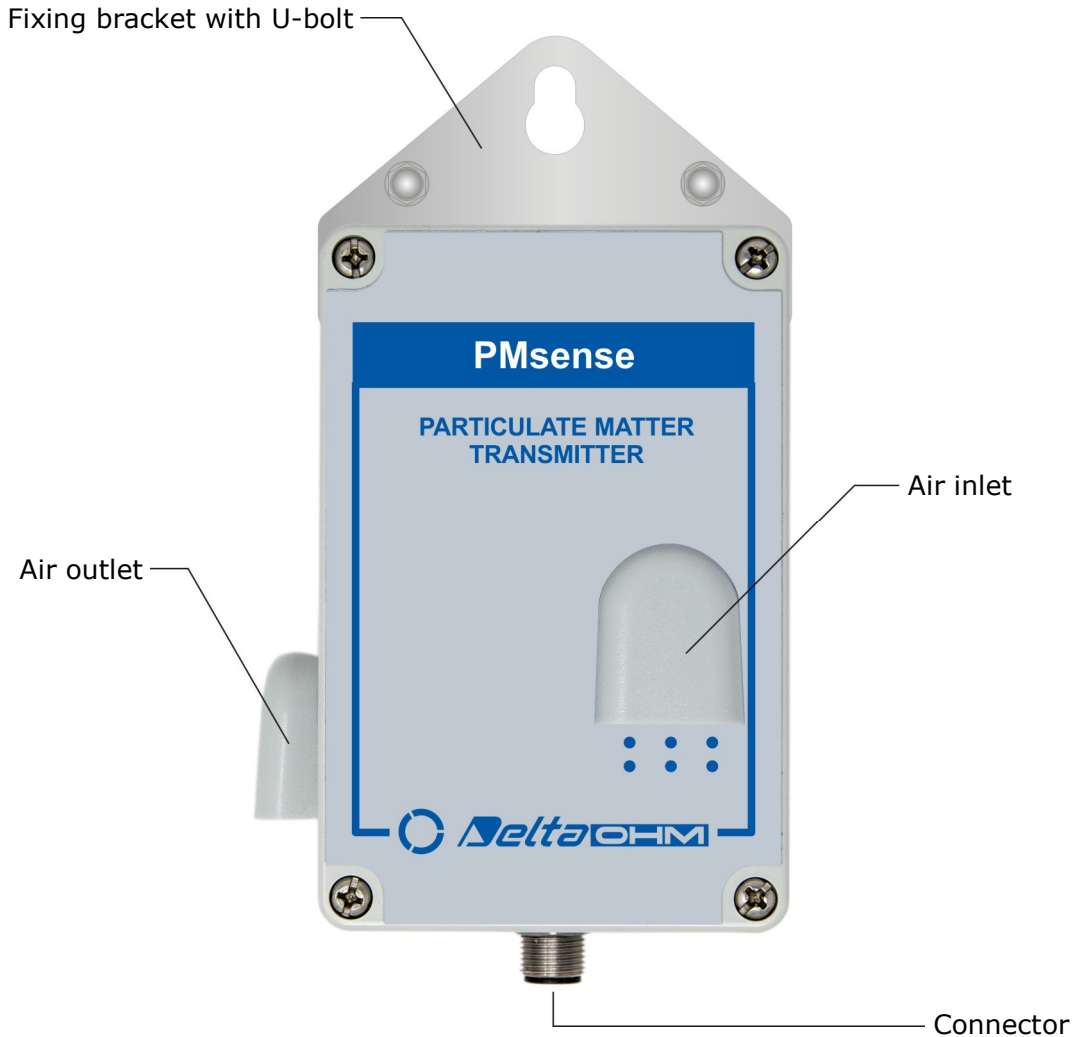

Fig. 3.1: transmitter description

3.1 ELECTRICAL CONNECTIONS

The transmitter has a M12 8-pole circular connector and uses the **CPM12-8PM... optional** cables, with M12 8-pole connector on one side and open wires on the other side.

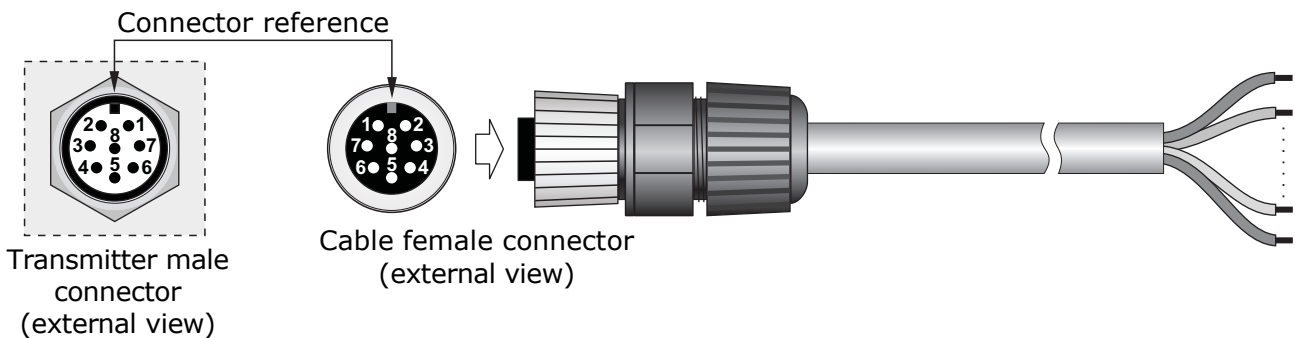

Fig. 3.2: connectors pinout

Connector pin N°	Function	CPM12-8PM... wire color
1	Power supply negative (GND)	Blue
2	Power supply positive (+Vdc)	Red
3	Not used	---
4	RS485 A/-	Brown
5	RS485 B/+	White
6	Digital and analog outputs ground (SGND)*	Grey
7	Analog output 1 positive (AOUT1, only PM[B]senseCR-A)	Yellow
8	Analog output 2 positive (AOUT2, only PM[B]senseCR-A)	Green
	Cable shield **	Black (thick wire)

* The output ground (SGND) and the negative of the power supply (GND) are short-circuited inside the transmitter.

* The cable shield is not connected to the M12 connector.

To ensure a good noise immunity, it is recommended to connect the cable shield to ground (GND).

RS485 connection:

By default, the instrument has MODBUS address **1** and communication parameters 19200, 8E1. Different parameters can be set using the proprietary protocol or the MODBUS-RTU protocol.

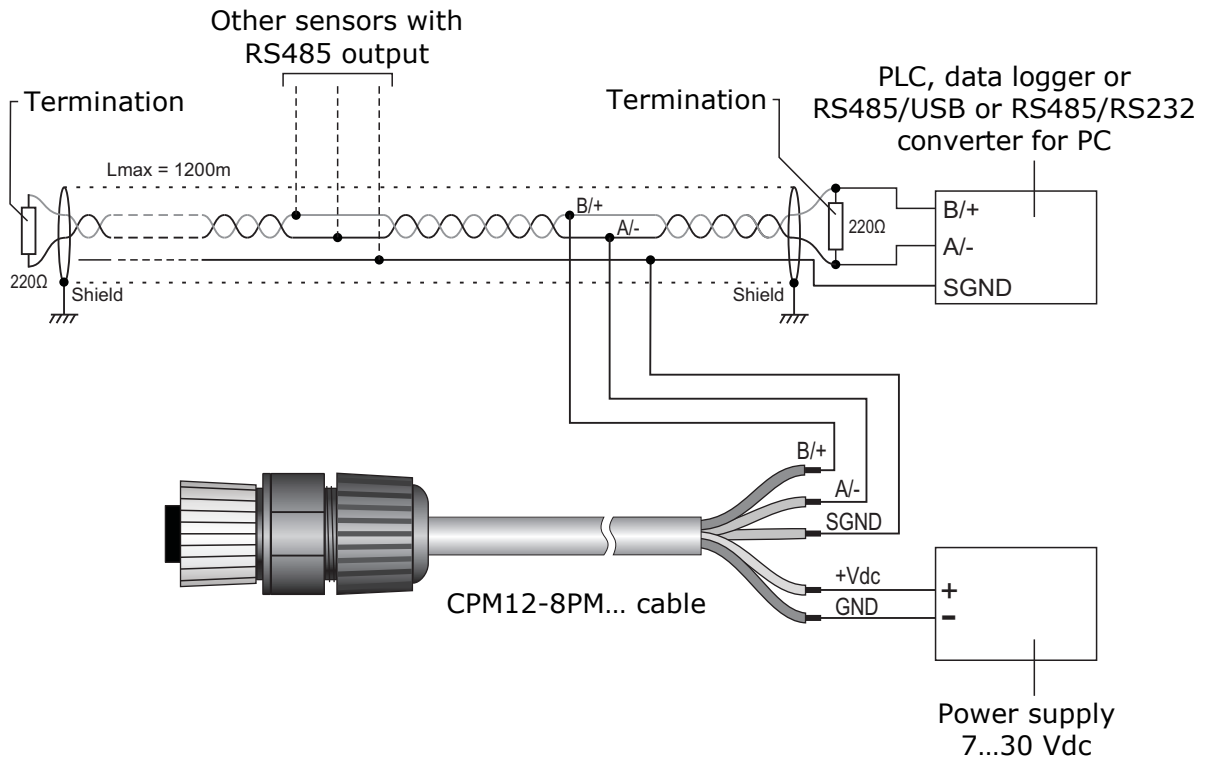

Fig. 3.3: RS485 connection

Current analog output (only PM[B]senseCR-A):

By default, the current analog outputs are 4...20 mA, with:

$$4 \text{ mA} = 0 \text{ pcs/m}^3$$

$$20 \text{ mA} = 10^9 \text{ pcs/m}^3$$

The analog output 1 is associated by default to N° of particles/m³ with size > 0.3 μm. The analog output 2 is associated by default to N° of particles/m³ with size > 0.5 μm.

With the commands of the proprietary protocol it is possible to associate the analog outputs to different parameters, set the range 0...20 mA for the output and reverse the direction of the output, so that the output decreases as the measurement increases.

In case of measurement error, the output goes to 22 mA.

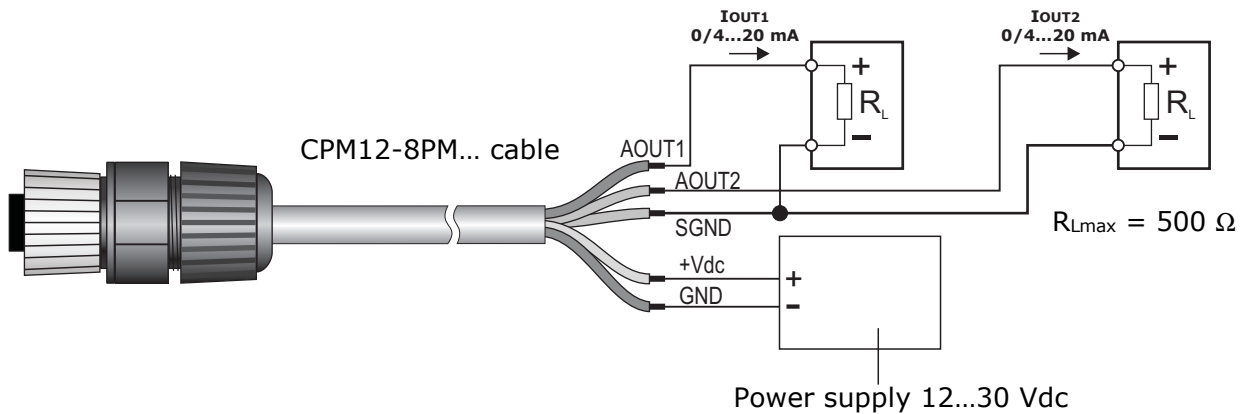

Fig. 3.4: current analog outputs connection

Voltage analog output (optional, only PM[B]senseCR-A):

By default, the voltage analog outputs are 0...10 V, with:

$$0 \text{ V} = 0 \text{ pcs/m}^3$$

$$10 \text{ V} = 10^9 \text{ pcs/m}^3$$

The analog output 1 is associated by default to N° of particles/m³ with size > 0.3 μm. The analog output 2 is associated by default to N° of particles/m³ with size > 0.5 μm.

With the commands of the proprietary protocol it is possible to associate the analog outputs to different parameters, set the range 2...10 V for the output and reverse the direction of the output, so that the output decreases as the measurement increases.

In case of measurement error, the output goes to 11 V.

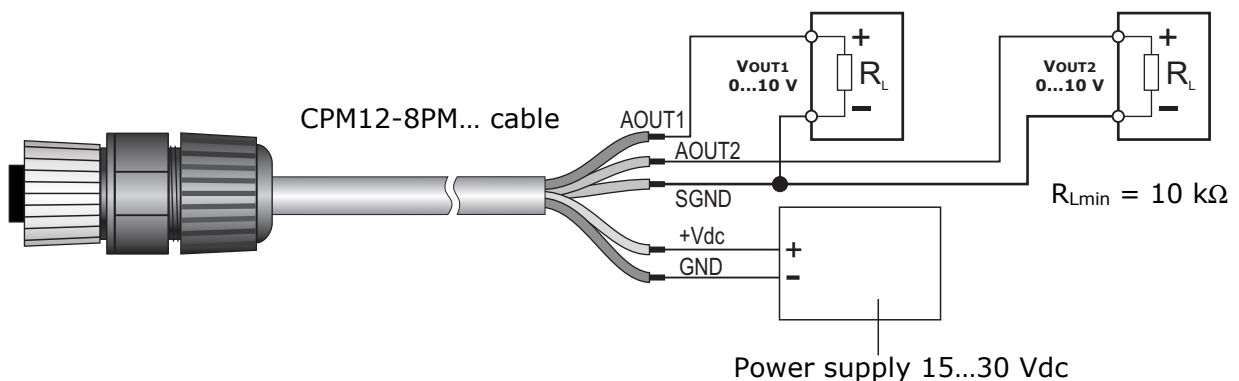

Fig. 3.5: voltage analog outputs connection

4 CONFIGURATION AND MEASUREMENT

The configuration of the instrument and the reading of the measurements can be done via the RS485 serial output, both with the proprietary protocol and with the MODBUS-RTU protocol.

In the first 10 seconds after the instrument power on, it is always active the proprietary protocol. After 10 seconds from power on, the operating protocol is activated, which by default is the MODBUS-RTU protocol.

It is possible to keep the proprietary protocol active even after 10 seconds from power on by sending, before the 10 seconds expire, the command @ of the proprietary protocol. The proprietary protocol can be set as operating protocol by means of the DP0 command.

The commands of the proprietary protocol and the registers of the MODBUS-RTU protocol are described in detail in the following chapters.

Particulate Matter measurement modes:

The transmitter can perform the PM measurement in continuous mode (default) or, in order to extend the sensor lifetime, at cyclic intervals.

In the measurement mode at cyclic intervals, the PM sensor is activated periodically for the ON time. The measurement is made available after 70 seconds from sensor activation (warm-up time). At the end of the ON time, the measurement is "frozen" and the sensor is deactivated until the set cyclic measurement interval expires.

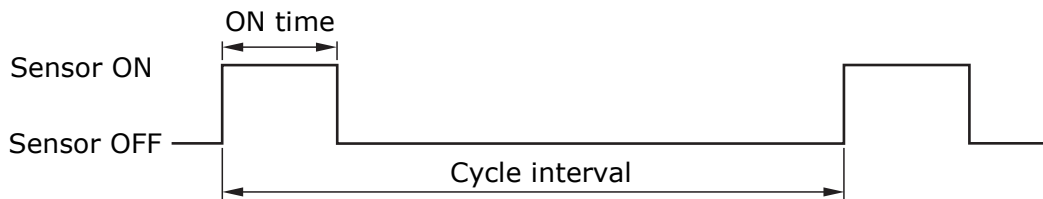

Fig. 4.1: Measurement mode at cyclic intervals

The measurement mode, the cycle interval and the sensor ON time can be configured respectively by using the CPLS, CPLP and CPLO commands of the proprietary protocol or the holding registers with address 15, 16 and 18 of the MODBUS-RTU protocol.

The transmitter provides three types of measurements:

- average over a 10 seconds interval, updated every second;
- average over a 60 seconds interval, updated every 10 seconds;
- average over a 15 min interval, updated every minute.

For the measurement mode at cyclic intervals, the cycle interval and the ON time must be set consistently with the desired averaging interval.

Status of the transmitter:

There are two LEDs on the internal electronic board of the transmitter: the **green LED** indicates the presence of the external power supply (blinks once per second), the **red LED** indicates the presence of any measurement errors (normally off, it blinks twice per second if at least one of the measured parameters is in error).

5 PROPRIETARY PROTOCOL

To use the proprietary protocol, it is necessary to connect the instrument to the PC via a RS485/USB (e.g. RS51K) or RS485/RS232 converter and use a standard serial communication program. In the serial communication program, set the COM port number to which the instrument is connected and the communication parameters as follows:

- If the MODBUS-RTU protocol is set as the operating protocol in the instrument (default), set the Baud Rate 57600 and the parameters 8N2 in the serial communication program, then power cycle the instrument and send the command @ within 10 seconds from the instrument power on.
- If the proprietary protocol is already set as the operating protocol in the instrument, it is possible to operate with Baud Rate 57600 and parameters 8N2 by sending the command @ within 10 seconds from the instrument power on, or you can let the 10 seconds pass without sending the command @ and operate with the communication parameters set in the instrument (default 19200, 8E1).

To change the instrument configuration, the serial command **CAL USER ON** must be sent first (the instrument replies with USER CAL MODE ON). The command CAL USER ON is automatically disabled after a few minutes of inactivity. If the settings should be only read, the command CAL USER ON is not required.

Below is the list of the serial commands.

Instrument information:

Command	Reply	Description
G0	<i>Model</i>	Instrument model
G1	<i>&Revision </i>	Instrument hardware revision
G2	SN=nnnnnnnn	Instrument serial number
G3	Firm.Ver.=x.y	Instrument firmware revision
G4	Firm.Date=yyyy/mm/dd	Date of firmware revision
GC	Fact.Calib.Date= yyyy/mm/dd User.Calib.Date= yyyy/mm/dd Cal.Mode= <i>Factory</i> or <i>User</i>	Date of factory calibration Date of user calibration (CO ₂ only) Type of calibration active (CO ₂ only)

Protocol:

Command	Reply	Description
@	&	Keeps the proprietary protocol operational even after 10 seconds from instrument power on. It must be sent within 10 seconds from instrument power on.
DPn	&	Sets the operating protocol: <ul style="list-style-type: none"> ▪ Proprietary if n=0 ▪ MODBUS-RTU if n=1 <i>Default</i> : MODBUS-RTU (n=1)
GP	& n	Reads the operating protocol set in the instrument.
SM	&	Activates the MODBUS-RTU protocol immediately.
CMA n	&	Sets the instrument address for the MODBUS-RTU protocol to n. The address should range within 1 and 247. <i>Default</i> : 1
RMA	& n	Reads the instrument address for the MODBUS-RTU protocol.

Note: after sending the DP1 command, the instrument remains with the proprietary protocol. Send the command SM to activate the MODBUS-RTU protocol immediately, or power cycle the instrument.

RS485 communication parameters:

Command	Reply	Description
CMBn	&	Sets the Baud Rate: <ul style="list-style-type: none"> ▪ 1200 if n=0 ▪ 2400 if n=1 ▪ 4800 if n=2 ▪ 9600 if n=3 ▪ 19200 if n=4 ▪ 38400 if n=5 ▪ 57600 if n=6 ▪ 115200 if n=7 <i>Default</i> : 19200 (n=4)
RMB	& n	Reads Baud Rate setting
CMpn	&	Sets parity and stop bits: <ul style="list-style-type: none"> ▪ 8N1 if n=0 [No parity, 1 stop bit] ▪ 8N2 if n=1 [No parity, 2 stop bits] ▪ 8E1 if n=2 [Even parity, 1 stop bit] ▪ 8E2 if n=3 [Even parity, 2 stop bits] ▪ 8O1 if n=4 [Odd parity, 1 stop bit] ▪ 8O2 if n=5 [Odd parity, 2 stop bits] The number of data bits is fixed to 8. <i>Default</i> : 8E1 (n=2)
RMP	& n	Reads the setting of parity and stop bits.
CMWn	&	Sets waiting time after transmission with MODBUS-RTU protocol: <ul style="list-style-type: none"> ▪ Immediate reception if n=0 (violates protocol) ▪ Waiting 3.5 characters if n=1 (respects protocol) <i>Default</i> : Immediate reception (n=0)
RMW	& n	Reads the setting of waiting time after transmission with MODBUS-RTU protocol.

PM measurement settings:

Command	Reply	Description
CPLSn	&	Sets the PM measurement mode: <ul style="list-style-type: none"> ▪ Continuous if n=0 ▪ At cyclic intervals if n=1 <i>Default</i> : Continuous (n=0)
RPLS	& n	Reads the setting of the PM measurement mode.
CPLPn	&	Sets the cycle interval for the measurement mode at cyclic intervals to n seconds. <i>Default</i> : 300 (=5 min)
RPLP	& n	Reads the setting of the cycle interval for the measurement mode at cyclic intervals.
CPLOn	&	Sets the sensor ON time for the measurement mode at cyclic intervals to n seconds. It must be greater than 70 s (warm-up time). <i>Default</i> : 71
RPLO	& n	Reads the setting of the sensor ON time for the measurement mode at cyclic intervals.

Reading of the measurement information:

Command	Reply	Description
CPSn	&	<p>Sets the type of PM measurement averaging for the analog outputs and the measurements sent by the transmitter in reply to P1, P5, S1 and S5 commands or when reading MODBUS Input Registers 1000...1008:</p> <ul style="list-style-type: none"> ▪ Average over a 10 seconds interval, updated every second if n=0 ▪ Average over a 60 seconds interval, updated every 10 seconds if n=1 ▪ Average over a 15 minutes interval, updated every minute if n=2 <p><i>Default</i> : Average over a 10 seconds interval, updated every second (n=0)</p>
RPS	& n	Reads the type of averaging for the measurements sent by the transmitter in reply to P1, P5, S1 and S5 commands.
P0	&	Disable the sending of the measurement enabled with P1.
P1	&	Enable the sending of the PM measurement every second (the sequence is the same described in command P5).
P5	& <i>Measurements</i>	<p>Prints the PM measurements in the following sequence:</p> <ul style="list-style-type: none"> ▪ PM measurement error (0=no, 1=yes) ▪ N° of particles/m³ with size > 0.3 µm ▪ N° of particles/m³ with size > 0.5 µm ▪ N° of particles/m³ with size > 1 µm ▪ N° of particles/m³ with size > 2.5 µm ▪ N° of particles/m³ with size > 5 µm <p><i>The PM measurement is averaged according to what is set with CPS command or MODBUS holding register 19.</i></p>
S0	&	Disable the sending of the measurement enabled with S1.
S1	&	Enable the sending of the measurement every second (the sequence is the same described in command S5).
S5	& <i>Measurements</i>	<p>Prints the measurements in the following sequence:</p> <ul style="list-style-type: none"> ▪ PM measurement error (0=no, 1=yes) ▪ N° of particles/m³ with size > 0.3 µm ▪ N° of particles/m³ with size > 0.5 µm ▪ N° of particles/m³ with size > 1 µm ▪ N° of particles/m³ with size > 2.5 µm ▪ N° of particles/m³ with size > 5 µm ▪ CO₂ in ppm ▪ Atmospheric pressure in hPa (internal sensor for CO₂ measurement compensation) ▪ <i>Field not used</i> ▪ <i>Field not used</i> ▪ <i>Field not used</i> ▪ Power supply voltage ▪ Internal board temperature <p><i>The PM measurement is averaged according to what is set with CPS command or MODBUS holding register 19.</i></p>

Analog outputs (only PM[B]senseCR-A):

Command	Reply	Description
CA1On	&	Enable/disable the offset of the analog output 1: <ul style="list-style-type: none"> ▪ Offset disabled if n=0 (0...20 mA or 0...10 V) ▪ Offset enabled if n=1 (4...20 mA or 2...10 V) <i>Default</i> : Offset enabled (n=1) if the output is current, offset disabled (n=0) if the output is voltage (optional)
RA1O	& n	Reads the setting of the offset for the analog output 1.
CA1SO	&	Sets the direct or inverse correspondence between analog output 1 and associated physical quantity: <ul style="list-style-type: none"> ▪ 4 mA/0 V \Rightarrow Min. quantity, 20 mA/10 V \Rightarrow Max. quantity if n=0 ▪ 20 mA/10 V \Rightarrow Min. quantity, 4 mA/0 V \Rightarrow Max. quantity if n=1 <i>Default</i> : Direct correspondence (n=0)
RA1SO	& n	Reads the type of correspondence (direct or inverse) between analog output 1 and associated physical quantity.
CA1Tn	&	Associates the analog output 1 to: <ul style="list-style-type: none"> ▪ CO₂ if n=12 (only PMBsenseCR-A) ▪ N° of particles/m³ with size > 0.3 μm if n=17 ▪ N° of particles/m³ with size > 0.5 μm if n=18 ▪ N° of particles/m³ with size > 1 μm if n=19 ▪ N° of particles/m³ with size > 2.5 μm if n=20 ▪ N° of particles/m³ with size > 5 μm if n=21 <i>Default</i> : N° of particles/m ³ with size > 0.3 μ m (n=17) <i>The PM measurement is averaged according to what is set with CPS command or MODBUS holding register 19.</i>
RA1T	& n	Reads the physical quantity associated to analog output 1.
CA1Ln	&	Sets n as the minimum value of the measuring range of the physical quantity associated to the analog output 1. <i>Default</i> : 0
RA1L	& n	Reads the minimum value of the measuring range of the physical quantity associated to the analog output 1.
CA1Hn	&	Sets n as the maximum value of the measuring range of the physical quantity associated to the analog output 1. <i>Default</i> : 1000000000 (=10 ⁹ pcs/m ³)
RA1H	& n	Reads the maximum value of the measuring range of the physical quantity associated to the analog output 1.
RA1F	& <i>Quantity</i> & <i>Minimum value</i> & <i>Maximum value</i>	Simultaneously provides the information obtainable with the RA1T, RA1L e RA1H commands.
CA2On	&	Enable/disable the offset of the analog output 2: <ul style="list-style-type: none"> ▪ Offset disabled if n=0 (0...20 mA or 0...10 V) ▪ Offset enabled if n=1 (4...20 mA or 2...10 V) <i>Default</i> : Offset enabled (n=1) if the output is current, offset disabled (n=0) if the output is voltage (optional)
RA2O	& n	Reads the setting of the offset for the analog output 2.

Command	Reply	Description
CA2SOn	&	Sets the direct or inverse correspondence between analog output 2 and associated physical quantity: <ul style="list-style-type: none"> ▪ 4 mA/0 V ⇒ Min. quantity, 20 mA/10 V ⇒ Max. quantity if n=0 ▪ 20 mA/10 V ⇒ Min. quantity, 4 mA/0 V ⇒ Max. quantity if n=1 <i>Default</i> : Direct correspondence (n=0)
RA2SO	& n	Reads the type of correspondence (direct or inverse) between analog output 2 and associated physical quantity.
CA2Tn	&	Associates the analog output 2 to: <ul style="list-style-type: none"> ▪ CO₂ if n=12 (only PMBsenseCR-A) ▪ N° of particles/m³ with size > 0.3 µm if n=17 ▪ N° of particles/m³ with size > 0.5 µm if n=18 ▪ N° of particles/m³ with size > 1 µm if n=19 ▪ N° of particles/m³ with size > 2.5 µm if n=20 ▪ N° of particles/m³ with size > 5 µm if n=21 <i>Default</i> : N° of particles/m ³ with size > 0.5 µm (n=18) <i>The PM measurement is averaged according to what is set with CPS command or MODBUS holding register 19.</i>
RA2T	& n	Reads the physical quantity associated to analog output 2.
CA2Ln	&	Sets n as the minimum value of the measuring range of the physical quantity associated to the analog output 2. <i>Default</i> : 0
RA2L	& n	Reads the minimum value of the measuring range of the physical quantity associated to the analog output 2.
CA2Hn	&	Sets n as the maximum value of the measuring range of the physical quantity associated to the analog output 2. <i>Default</i> : 1000000000 (=10 ⁹ pcs/m ³)
RA2H	& n	Reads the maximum value of the measuring range of the physical quantity associated to the analog output 2.
RA2F	& <i>Quantity</i> <i>Minimum value</i> <i>Maximum value</i>	Simultaneously provides the information obtainable with the RA2T, RA2L e RA2H commands.

CO₂ calibration (only PMBsenseCR...):

A 2-point (CO21 and CO22 commands) or 1-point calibration (CO20 command) can be performed. The points are chosen by the user. To perform the calibration, the transmitter must be placed in an environment with a known CO₂ concentration.

While the 2-point calibration allows moving the two calibration points independently, and therefore also to adjust the slope of the sensor response curve, the 1-point calibration simply adds an offset to the measurement (the two calibration points are shifted of the same amount) and is typically accomplished by placing the transmitter in clean air.

Before performing the calibration, the type of calibration to be used must be set to "user" with the CC command.

The transmitter allows manually setting, with the DA command, a string that is saved as the date and time of the calibration. The string must be set before performing the calibration.

Command	Reply	Description
CO21n	& t	CO ₂ calibration in the first point at n ppm. The transmitter must first be placed in an environment with a known CO ₂ concentration (the value n entered in the command). The value t in the reply to the command indicates the number of seconds required for the transmitter to complete the calibration operation. During this time, the transmitter sends strings notifying the progress of the operation; for example: "CO2 calib. Status:IN PROGRESS 8% Avg:1096ppm Dev:0ppm" At the end, the OK 100% notification indicates that the operation was successful; for example: "CO2 calib. Status:OK 100% Avg:1100ppm Dev:7ppm"
CO22n	& t	CO ₂ calibration in the second point at n ppm. Operation similar to the CO21command.
CO20n	& t	CO ₂ calibration at n ppm (1-point calibration – offset adjustment). Operation similar to the CO21command.
DAyyyy/mm/dd hh:mm:ss	&	Saves the string "aaaa/mm/gg hh:mm:ss" as the date and time when calibration is performed. The command must be sent before performing the calibration.
GA	& yyyy/mm/dd hh:mm:ss	Reads the date and time saved with the DA command.
CCn	&	Sets the type of calibration to be used: <ul style="list-style-type: none">▪ User if n=0▪ Factory if n=1 <i>Default : Factory (n=1)</i>
CO2D	&	Reset of user calibration.

Restoring the factory configuration:

Command	Reply	Description
DFLT	&	Restores the factory configuration.

6 MODBUS-RTU PROTOCOL

By default, the instrument has MODBUS address **1** and communication parameters 19200, 8E1. The address and the communication parameters can be changed by using the appropriate serial commands of the proprietary protocol or, alternatively, directly with MODBUS commands by changing the value of the Coils and Holding Registers described later.

The MODBUS-RTU protocol, if set as the operating protocol (default), is active after 10 seconds from the instrument power on.

In order to change the instrument configuration using the MODBUS-RTU protocol, the value 1 must be written first in the *Coil* with address 1.

Below is the list of registers.

Input Registers:

Address	Description	Format
26	PM measurement error: 0=no, 1=yes.	16-bit Integer
28	CO ₂ in ppm.	16-bit Integer
33	Atmospheric pressure in Pa <i>Internal sensor for CO₂ measurement compensation</i>	32-bit Integer
35	Atmospheric pressure in hPa (x10) <i>Internal sensor for CO₂ measurement compensation</i>	16-bit Integer
37	Power supply voltage in Volt (x10).	16-bit Integer
38	Internal board temperature (x10).	16-bit Integer
40	Instrument firmware revision. The most significant byte indicates the major revision; the less significant byte indicates the minor revision.	16-bit Integer
41	Number of MODBUS communication error.	16-bit Integer
1000	N° of particles/m ³ with size > 0.3 µm. <i>Measurement averaged according to what is set with CPS command or MODBUS holding register 19.</i>	32-bit Unsigned Integer
1002	N° of particles/m ³ with size > 0.5 µm. <i>Measurement averaged according to what is set with CPS command or MODBUS holding register 19.</i>	32-bit Unsigned Integer
1004	N° of particles/m ³ with size > 1 µm. <i>Measurement averaged according to what is set with CPS command or MODBUS holding register 19.</i>	32-bit Unsigned Integer
1006	N° of particles/m ³ with size > 2.5 µm. <i>Measurement averaged according to what is set with CPS command or MODBUS holding register 19.</i>	32-bit Unsigned Integer
1008	N° of particles/m ³ with size > 5 µm. <i>Measurement averaged according to what is set with CPS command or MODBUS holding register 19.</i>	32-bit Unsigned Integer
1010	N° of particles/m ³ with size > 0.3 µm. <i>Measurement averaged over 10 s and updated every second.</i>	32-bit Unsigned Integer

Address	Description	Format
1012	N° of particles/m ³ with size > 0.5 µm. <i>Measurement averaged over 10 s and updated every second.</i>	32-bit Unsigned Integer
1014	N° of particles/m ³ with size > 1 µm. <i>Measurement averaged over 10 s and updated every second.</i>	32-bit Unsigned Integer
1016	N° of particles/m ³ with size > 2.5 µm. <i>Measurement averaged over 10 s and updated every second.</i>	32-bit Unsigned Integer
1018	N° of particles/m ³ with size > 5 µm. <i>Measurement averaged over 10 s and updated every second.</i>	32-bit Unsigned Integer
1020	N° of particles/m ³ with size > 0.3 µm. <i>Measurement averaged over 60 s and updated every 10 s.</i>	32-bit Unsigned Integer
1022	N° of particles/m ³ with size > 0.5 µm. <i>Measurement averaged over 60 s and updated every 10 s.</i>	32-bit Unsigned Integer
1024	N° of particles/m ³ with size > 1 µm. <i>Measurement averaged over 60 s and updated every 10 s.</i>	32-bit Unsigned Integer
1026	N° of particles/m ³ with size > 2.5 µm. <i>Measurement averaged over 60 s and updated every 10 s.</i>	32-bit Unsigned Integer
1028	N° of particles/m ³ with size > 5 µm. <i>Measurement averaged over 60 s and updated every 10 s.</i>	32-bit Unsigned Integer
1030	N° of particles/m ³ with size > 0.3 µm. <i>Measurement averaged over 15 min and updated every minute.</i>	32-bit Unsigned Integer
1032	N° of particles/m ³ with size > 0.5 µm. <i>Measurement averaged over 15 min and updated every minute.</i>	32-bit Unsigned Integer
1034	N° of particles/m ³ with size > 1 µm. <i>Measurement averaged over 15 min and updated every minute.</i>	32-bit Unsigned Integer
1036	N° of particles/m ³ with size > 2.5 µm. <i>Measurement averaged over 15 min and updated every minute.</i>	32-bit Unsigned Integer
1038	N° of particles/m ³ with size > 5 µm. <i>Measurement averaged over 15 min and updated every minute.</i>	32-bit Unsigned Integer

To read a 32-bit value, two consecutive registers must be accessed (e.g. 1010 and 1011 to read the number of particles/m³ with size > 0.3 µm averaged over 10 s). The register with lower address contains the most significant bits.

Coils:

Address	Description	Format
0	Set 1 to restore the factory configuration. Bit zeroing is automatic.	Bit
1	Enable configuration change: 0=no (default), 1=yes. The changes to <i>Coils</i> and <i>Holding Registers</i> will be accepted only if this register is set to 1.	Bit
2	Sets waiting time after transmission with MODBUS-RTU protocol: 0=immediate reception (default); 1=waiting 3.5 characters.	Bit
3	Enable/disable the offset of the analog output 1: 0=offset disabled (0...20 mA or 0...10 V, default if the output is voltage); 1=offset enabled (4...20 mA or 2...10 V, default if the output is current).	Bit
4	Sets the direct or inverse correspondence between analog output 1 and associated physical quantity: 0=4 mA/0 V ⇒ Min. quantity, 20 mA/10 V ⇒ Max. quantity (default); 1=20 mA/10 V ⇒ Min. quantity, 4 mA/0 V ⇒ Max. quantity.	Bit
5	Enable/disable the offset of the analog output 2: 0=offset disabled (0...20 mA or 0...10 V, default if the output is voltage); 1=offset enabled (4...20 mA or 2...10 V, default if the output is current).	Bit
6	Sets the direct or inverse correspondence between analog output 2 and associated physical quantity: 0=4 mA/0 V ⇒ Min. quantity, 20 mA/10 V ⇒ Max. quantity (default); 1=20 mA/10 V ⇒ Min. quantity, 4 mA/0 V ⇒ Max. quantity.	Bit

Holding Registers:

Address	Description	Format
0	RS485 Baud Rate: 0=1200; 1=2400; 2=4800; 3=9600; 4=19200 (default); 5=38400; 6=57600; 7=115200.	16-bit Integer
1	RS485 parity and stop bits: 0=8N1; 1=8N2; 2=8E1 (default); 3=8E2; 4=8O1; 5=8O2. [N=no parity, E=even parity, O=odd parity]	16-bit Integer
2	Instrument address for the MODBUS-RTU protocol (1...247, default=1).	16-bit Integer
3	Association of a physical quantity to the analog output 1: 12=CO ₂ (only PMBsenseCR-A); 17= N° of particles/m ³ with size > 0.3 µm (default); 18= N° of particles/m ³ with size > 0.5 µm; 19= N° of particles/m ³ with size > 1 µm; 20= N° of particles/m ³ with size > 2.5 µm; 21= N° of particles/m ³ with size > 5 µm. <i>The PM measurement is averaged according to what is set with CPS command or MODBUS holding register 19.</i>	16-bit Integer
6	Setting of the minimum value of the measuring range of the physical quantity associated to the analog output 1. The default value is 0.	32-bit Integer
8	Setting of the maximum value of the measuring range of the physical quantity associated to the analog output 1. The default value is 1000000000 (=10 ⁹ pcs/m ³).	32-bit Integer
10	Association of a physical quantity to the analog output 2: 12=CO ₂ (only PMBsenseCR-A); 17= N° of particles/m ³ with size > 0.3 µm; 18= N° of particles/m ³ with size > 0.5 µm (default); 19= N° of particles/m ³ with size > 1 µm; 20= N° of particles/m ³ with size > 2.5 µm; 21= N° of particles/m ³ with size > 5 µm. <i>The PM measurement is averaged according to what is set with CPS command or MODBUS holding register 19.</i>	16-bit Integer
11	Setting of the minimum value of the measuring range of the physical quantity associated to the analog output 2. The default value is 0.	32-bit Integer
13	Setting of the maximum value of the measuring range of the physical quantity associated to the analog output 2. The default value is 1000000000 (=10 ⁹ pcs/m ³).	32-bit Integer

Address	Description	Format
15	Setting of the PM measurement mode: 0=continuous (default); 1=at cyclic intervals.	16-bit Integer
16	Setting of the cycle interval, in seconds, for the PM measurement mode at cyclic intervals. The default value is 300 (=5 min).	16-bit Unsigned Integer
18	Setting of the sensor ON time, in seconds, for the PM measurement mode at cyclic intervals. It must be greater than 70 s (warm-up time). The default value is 71.	16-bit Unsigned Integer
19	Setting of the type of PM measurement averaging for the analog outputs and the measurements sent by the transmitter in reply to P1, P5, S1 and S5 commands (proprietary protocol) or when reading MODBUS Input Registers 1000...1008: 0=average over a 10 seconds interval, updated every second (default); 1=average over a 60 seconds interval, updated every 10 seconds; 2=average over a 15 minutes interval, updated every minute.	16-bit Integer
20	Setting of the type of CO ₂ calibration to be used: 0=user; 1=factory (default).	16-bit Integer

For 32-bit values, two consecutive registers must be accessed (e.g. 6 and 7 for the setting of the minimum value of the measuring range of the physical quantity associated to the analog output 1). The register with lower address contains the most significant bits.

7 SAFETY INSTRUCTIONS

General safety instructions

The instrument has been manufactured and tested in accordance with the safety standard EN61010-1:2010 "Safety requirements for electrical equipment for measurement, control and laboratory use" and has left the factory in perfect safety technical conditions.

The instrument proper operation and operating safety can be ensured only if all standard safety measures as well as the specific measures described in this manual are followed.

The instrument proper operation and operating safety can be ensured only in the climatic conditions specified in this manual.

Do not use the instruments in places where there are:

- Corrosive or flammable gases.
- Direct vibrations or shocks to the instrument.
- High-intensity electromagnetic fields, static electricity.

User obligations

The instrument operator shall follow the directives and regulations below that refer to the treatment of dangerous materials:

- EEC directives on workplace safety.
- National law regulations on workplace safety.
- Accident prevention regulations.

8 ACCESSORIES ORDERING CODES

- CPM12-8PM.x** Cable with 8-pole M12 connector on one end, open wires on the other end. Length 2 m (CPM12-8PM.2), 5 m (CPM12-8PM.5) or 10 m (CPM12-8PM.10) standard, other lengths on request.
- RS51K** Kit for connecting the transmitter RS485 output to a PC. It includes the SWD10 power supply and the RS485/USB adapter with:
- screw terminals for the connection to the CPM12-8PM.x cable (not included);
 - USB connector for the connection to the PC;
 - jack connector for connecting the SWD10 power supply.

NOTES

**DICHIARAZIONE DI CONFORMITÀ UE**
EU DECLARATION OF CONFORMITY**Delta Ohm S.r.L. a socio unico – Via Marconi 5 – 35030 Caselle di Selvazzano – Padova – ITALY**Documento Nr. / Mese.Anno: **5178 / 02.2021**
Document-No. / Month.Year :

Si dichiara con la presente, in qualità di produttore e sotto la propria responsabilità esclusiva, che i seguenti prodotti sono conformi ai requisiti di protezione definiti nelle direttive del Consiglio Europeo:
We declare as manufacturer herewith under our sole responsibility that the following products are in compliance with the protection requirements defined in the European Council directives:

Codice prodotto: **PMsenseCR-M / PMBsenseCR-M**
Product identifier : **PMsenseCR-A / PMBsenseCR-A**Descrizione prodotto: **Trasmettitori di Particolato (PM) e CO₂**
Product description : **Particulate Matter (PM) and CO₂ transmitters**I prodotti sono conformi alle seguenti Direttive Europee:
The products conform to following European Directives:

Direttive / Directives	
2014/30/EU	Direttiva EMC / EMC Directive
2014/35/EU	Direttiva bassa tensione / Low Voltage Directive
2011/65/EU - 2015/863/EU	RoHS / RoHS

Norme armonizzate applicate o riferimento a specifiche tecniche:
Applied harmonized standards or mentioned technical specifications:

Norme armonizzate / Harmonized standards	
EN 61010-1:2010	Requisiti di sicurezza elettrica / Electrical safety requirements
EN 61326-1:2013	Requisiti EMC / EMC requirements
EN 50581:2012	RoHS / RoHS

Il produttore è responsabile per la dichiarazione rilasciata da:
The manufacturer is responsible for the declaration released by:

Alessandro Perego

Amministratore delegato
Chief Executive Officer

Caselle di Selvazzano, 18/02/2021

Questa dichiarazione certifica l'accordo con la legislazione armonizzata menzionata, non costituisce tuttavia garanzia delle caratteristiche.
This declaration certifies the agreement with the harmonization legislation mentioned, contained however no warranty of characteristics.

WARRANTY

Delta OHM is required to respond to the "factory warranty" only in those cases provided by Legislative Decree 6 September 2005 - n. 206. Each instrument is sold after rigorous inspections; if any manufacturing defect is found, it is necessary to contact the distributor where the instrument was purchased from. During the warranty period (24 months from the date of invoice) any manufacturing defects found will be repaired free of charge. Misuse, wear, neglect, lack or inefficient maintenance as well as theft and damage during transport are excluded. Warranty does not apply if changes, tampering or unauthorized repairs are made on the product. Solutions, probes, electrodes and microphones are not guaranteed as the improper use, even for a few minutes, may cause irreparable damages.

Delta OHM repairs the products that show defects of construction in accordance with the terms and conditions of warranty included in the manual of the product. For any dispute, the competent court is the Court of Padua. The Italian law and the "Convention on Contracts for the International Sales of Goods" apply.

TECHNICAL INFORMATION

The quality level of our instruments is the result of the continuous product development. This may lead to differences between the information reported in the manual and the instrument you have purchased. In case of discrepancies and/or inconsistencies, please write to sales@deltaohm.com. Delta OHM reserves the right to change technical specifications and dimensions to fit the product requirements without prior notice.

DISPOSAL INFORMATION

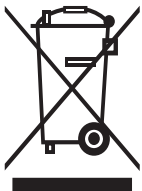

Electrical and electronic equipment marked with specific symbol in compliance with 2012/19/EU Directive must be disposed of separately from household waste. European users can hand them over to the dealer or to the manufacturer when purchasing a new electrical and electronic equipment, or to a WEEE collection point designated by local authorities. Illegal disposal is punished by law.

Disposing of electrical and electronic equipment separately from normal waste helps to preserve natural resources and allows materials to be recycled in an environmentally friendly way without risks to human health.



V1.0
09/2021