

OPERATING MANUAL

PBS860 / PBS880

Barometric
transmitters

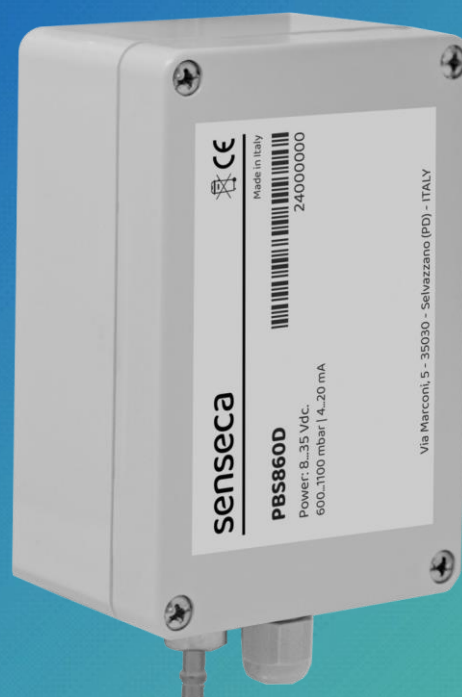

EN
V1.0

Contents

1	Introduction	3
2	Technical specifications.....	4
3	Installation.....	5
	3.1 Electrical connections	6
4	Maintenance	7
5	Safety instructions	7
6	Accessories ordering codes	8

1 Introduction

PBS860 and **PBS880** are barometric transmitters equipped with a precision temperature-compensated piezo-resistive pressure sensor.

PBS860 and PBS880 differ in the measuring range: 600...1100 hPa for PBS860, 800...1100 hPa for PBS880.

The sensor is factory calibrated and has excellent time stability and repeatability.

Depending on model, the transmitters have 2-wire (current loop) 4...20 mA, 0...1 V, 0...5 V or 0...10 V analog output.

Available as an accessories a **static port** with support bracket to minimize the effect of dynamic pressure due to the wind in open field measurements.

The table below highlights the measuring range and the type of output of the various models.

Model	Measuring range	Analog output
PBS860D	600...1100 hPa	2-wire (current loop) 4...20 mA
PBS860W		0...1 V
PBS860X		0...5 V
PBS860Y		0...10 V
PBS880D	800...1100 hPa	2-wire (current loop) 4...20 mA
PBS880W		0...1 V
PBS880X		0...5 V
PBS880Y		0...10 V

2 Technical specifications

Sensor	Piezoresistive
Measuring range	PBS860: 600...1100 hPa PBS880: 800...1100 hPa
Accuracy	± 0.5 hPa @ 20 °C
Temperature drift	Zero: < 1% F.S. / Span: < 1% F.S. @ T=-20...+60 °C
Long-term stability	< 0.25% F.S./6 months @ 20 °C
Output	Depending on model: 2-wire (current loop) 4...20 mA 0...1 V, 0...5 V or 0...10 V Current output load resistance: $R_L < (V_{dc}-7)/0,022$ Voltage output load resistance: $R_L > 10 \text{ k}\Omega$
Power supply	8...35 Vdc (except PBS8x0Y) 15...30 Vdc (only PBS8x0Y)
Consumption	<4 mA @ 24 Vdc for voltage output versions Equal to output current for current output version
Connection	Internal screw terminal header / PG7 cable gland for power supply and output
Operating conditions	-30...+60 °C / 0...100%RH
Compatible media	Air and dry gases
Materials	Transmitter: Polycarbonate, pressure input in AISI 304 Static port (optional): ASA Support bracket (optional): Aluminium alloy
Housing dimensions	120 x 80 x 55
Weight	250 g approx. 570 g approx. the static port with support bracket
Protection degree	IP65

3 Installation

The transmitter is wall mounted using the two holes on the back (open the cover to access the holes and the terminal header for electrical connections).

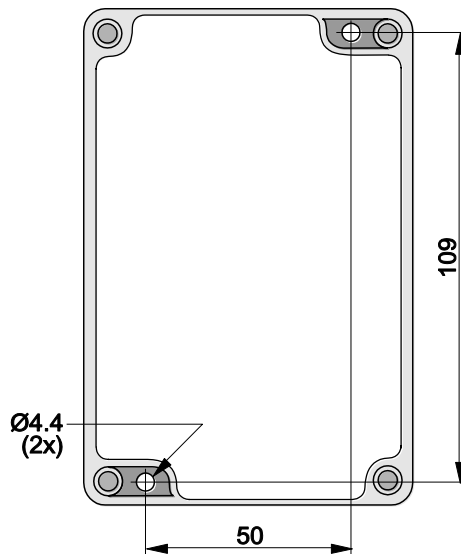

Fig. 3.1: fixing holes

It is advisable to mount the transmitter so that the pressure input is facing downwards, in order to reduce the accumulation of dust and dirt on the input.

For outdoor installation, the use of the optional static pressure port is recommended, in order to minimize the measurement error caused by the wind flow on the pressure input (the measurement deviation due to wind is less than 0.3 hPa @ 20 m/s if the static port is used). The static port includes a support bracket suitable for fixing to a Ø30...50 mm mast.

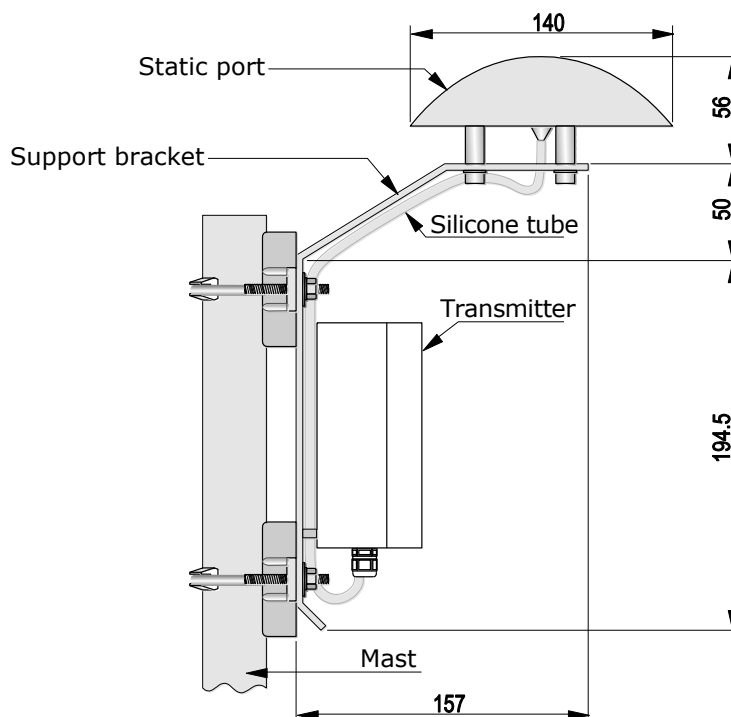

Fig. 3.2: transmitter with static pressure port

3.1 Electrical connections

The transmitter has an internal screw terminal header for connecting the power supply and the output.

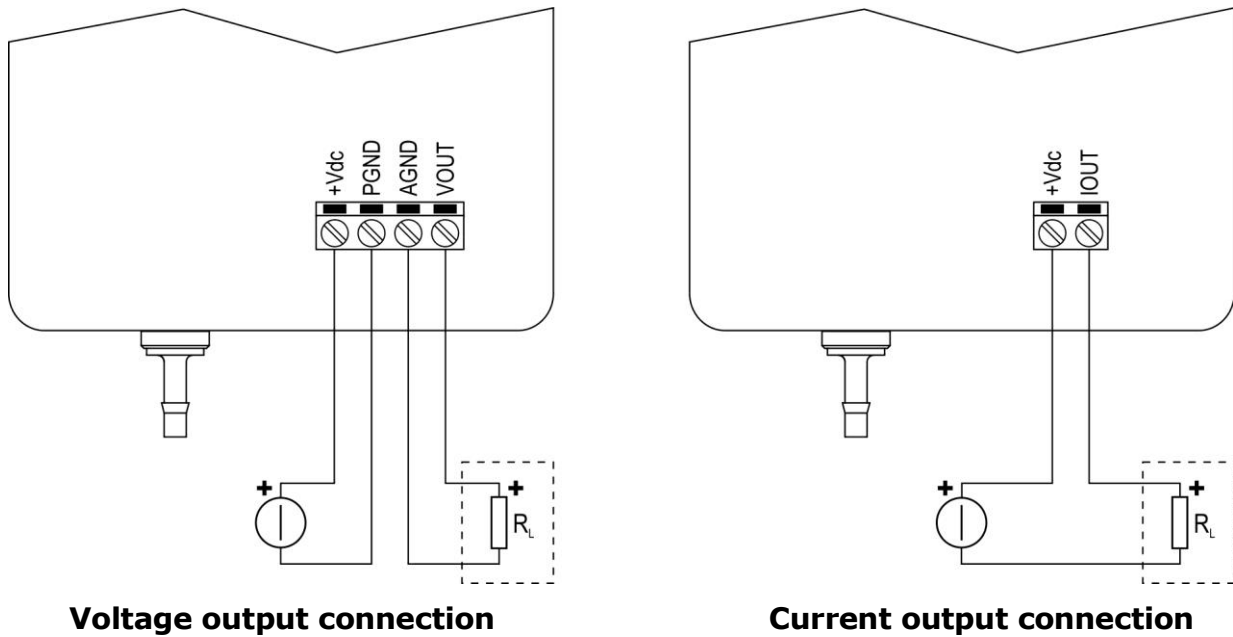

Fig. 3.3: connections

4 Maintenance

it is recommended to perform a calibration check of the instrument annually at accredited laboratories.

Do not use aggressive cleaning agents or incompatible with the materials indicated in the technical specifications. For cleaning, use a soft dry cloth or slightly dampened with clean water.

5 Safety instructions

The instrument proper operation and operating safety can be ensured only in the climatic conditions specified in this manual and if all standard safety measures as well as the specific measures described in this manual are followed.

Do not use the instruments in places where there are:

- Corrosive or flammable gases.
- Direct vibrations or shocks to the instrument.
- High-intensity electromagnetic fields, static electricity.

User obligations

The instrument operator shall follow the directives and regulations below that refer to the treatment of dangerous materials:

- EU directives on workplace safety.
- National law regulations on workplace safety.
- Accident prevention regulations.

6 Accessories ordering codes

- FIXB001** Static port with support bracket and silicone tube.
- SWD10F** 100...240 Vac / 12 Vdc – 1A power supply. Includes adapter cable with jack connector on the power supply side and free wires on the instrument side.

NOTES

NOTES

WARRANTY

The manufacturer is required to respond to the "factory warranty" only in those cases provided by Legislative Decree 6 September 2005 - n. 206. Each instrument is sold after rigorous inspections; if any manufacturing defect is found, it is necessary to contact the distributor where the instrument was purchased from. During the warranty period (24 months from the date of invoice) any manufacturing defects found will be repaired free of charge. Misuse, wear, neglect, lack or inefficient maintenance as well as theft and damage during transport are excluded. Warranty does not apply if changes, tampering or unauthorized repairs are made on the product. Solutions, probes, electrodes and microphones are not guaranteed as the improper use, even for a few minutes, may cause irreparable damages.

The manufacturer repairs the products that show defects of construction in accordance with the terms and conditions of warranty included in the manual of the product. For any dispute, the competent court is the Court of Padua. The Italian law and the "Convention on Contracts for the International Sales of Goods" apply.

TECHNICAL INFORMATION

The quality level of our instruments is the result of the continuous product development. This may lead to differences between the information reported in the manual and the instrument you have purchased.

We reserve the right to change technical specifications and dimensions to fit the product requirements without prior notice.

DISPOSAL INFORMATION

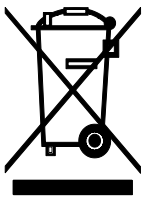

Electrical and electronic equipment marked with specific symbol in compliance with 2012/19/EU Directive must be disposed of separately from household waste. European users can hand them over to the dealer or to the manufacturer when purchasing a new electrical and electronic equipment, or to a WEEE collection point designated by local authorities. Illegal disposal is punished by law.

Disposing of electrical and electronic equipment separately from normal waste helps to preserve natural resources and allows materials to be recycled in an environmentally friendly way without risks to human health.



senseca.com



Senseca Italy S.r.l.
Via Marconi, 5
35050 Selvazzano Dentro (PD)
ITALY
info@senseca.com

